

# SEZIONE 3/SECTION 3



**UGELLI  
ASSIALI E TANGENZIALI  
A CONO PIENO  
AXIAL AND TANGENTIAL-FEED  
FULL-CONE NOZZLES**



## Sezioni

Il catalogo è suddiviso in sezioni contraddistinte da colori diversi, ogni colore identifica un particolare tipo di getto.

All'inizio di ogni sezione, una serie di informazioni tecniche potrà aiutarvi ad individuare il tipo di ugello più adatto alle vostre esigenze.

<b>GETTO A CONO VUOTO</b>	<b>GETTO A CONO VUOTO TANGENZIALE</b>	<b>GETTO A CONO PIENO</b>	<b>GETTO PIATTO E GETTO RETTILINEO</b>	<b>GETTO ATOMIZZATO</b>	<b>ACCESSORI</b>
<b>HOLLOW-CONE JET</b>	<b>TANGENTIAL FEED HOLLOW-CONE JET</b>	<b>FULL-CONE JET</b>	<b>VEE-JET AND RECTILINEAR JET</b>	<b>ATOMIZED-JET</b>	<b>ACCESSORIES</b>

## Sections

For your easy reference we have divided our brochure into sections, marked by different colours, every colour identifies a particular shape of jet.

At the beginning of every section you will find the technical information, that will assist you in choosing the correct nozzle design for your applications.

## Dimensione orifizi

Le dimensioni degli orifizi sono espresse in mm e i valori indicati sono nominali.

## Orifices dimensions

The dimensions of the orifices are indicated in mm and the values are nominal.

## Raccordo filettato

Tutti gli ugelli sono forniti con raccordo standard GAS CILINDRICO (BSP) o GAS CONICO (BSPT).  
Filettature NPT o altre a richiesta.

## Threaded connection

All our nozzles have standard PARALLEL GAS thread (BSP) or CONICAL GAS thread (BSPT).  
NPT thread or other thread on request.

## Legenda

- Ø E = Massimo diametro di passaggio libero, affinché le particelle sospese nel liquido non intasino l'ugello.
- Ø U = Diametro nominale dell'orifizio.
- Ø O = Diametro nominale equivalente.
- X = Raccordo filettato femmina.
- Y = Raccordo filettato maschio.

## Key

- Ø E = The maximum diameter of free passage, so that the solid particles in the sprayed liquid do not clog the nozzle.
- Ø U = The nominal diameter of the orifice.
- Ø O = The equivalent nominal diameter.
- X = Female thread connection.
- Y = Male thread connection.

## Tabelle dati operativi

Le tabelle delle portate riportano nella colonna evidenziata in azzurro la portata rilevata alla pressione di 2 bar, che è la pressione di riferimento in fase di collaudo del prodotto. Le portate relative a pressioni differenti esposte nelle tabelle sono il risultato di un calcolo matematico. A richiesta è possibile collaudare gli ugelli a pressioni differenti (da 0,5 a 100 bar).

## Operative data tables

The flows tables report on the blue column the flow measured at 2 bar, that is the datum flow during the production tests. Flow values at different pressures have been calculated. We can test our nozzles at different pressure (from 0,5 to 100 bar) on request.

## DATI OPERATIVI - OPERATIVE DATA

TIPO OCy - Dimensione raccordo OCy TYPE - Thread dimension				CODICE PORTATA FLOW CODE	PORTATA / FLOW l/min										
3/4"	1"	1"1/4	1"1/2		Ø E mm.	Ø U mm.	0,5 bar	1 bar	1,5 bar	2 bar	3 bar	4 bar	5 bar	7 bar	10 bar
▼				240	5,0	4,6	8,6	11,4	13,4	15	17,6	20	22	25	29
▼				260	5,5	5,0	9,8	12,9	15,2	17	20	22	25	28	32
▼				270	5,8	5,5	10,3	13,6	16,0	18	21	24	26	30	34
				320	5,0	5,0	10,0	12,5	15,0	17,5	20,0	22,5	25,0	27,5	30,0



**È facile ordinare**

Dalle tabelle è possibile recuperare tutti i dati necessari per l'ordinazione.

Ecco un esempio di come ordinare un ugello a cono pieno serie OC, raccordo maschio da 2" 1/2, portata 152 l/min., pressione 2 bar, angolo 90°, materiale AISI 316 (vedi pag 45):

**It's easy to pass an order**

You can find on the flow tables all data to pass an order. For example you want to order a full-cone nozzle OC serie, male connection, 2" 1/2 thd., flow 152 l/min., pressure 2 bar, spray angle 90°, material AISI 316 (see page 45):

**OC y 2" 1/2 632 90° AISI 316**

**DATI OPERATIVI - OPERATIVE DATA**

TIPO OCx-y - Dimensione raccordo OCx-y TYPE - Thread dimension			CODICE PORTATA FLOW CODE	PORTATA / FLOW l/min											AMPIEZZA ANGOLO DI SPRUZZO SPRAY ANGLE WIDTH	
2"	2"1/2	3"		Ø E mm.	Ø U mm.	0,5 bar	1 bar	1,5 bar	2 bar	3 bar	4 bar	5 bar	7 bar	10 bar	90°	120°
▼			576	10,0	14,0	67	89	104	117	138	154	169	193	223	●	●
▼			622	11,0	14,5	82	108	127	142	167	187	205	234	270	●	●
▼	▼		632	12,5	15,0	87	115	135	152	179	201	219	251	289	●	●
▼			650	12,5	15,5	98	125	145	170	200	224	245	281	320	●	●

**Codici materiali**

Cod.	Descr.
01	FERRO - CARBON STEEL
02	AISI 316 S.S.
03	AISI 316L S.S.
04	AISI 303 S.S.
05	AISI 304 S.S.
06	OTTONE - BRASS
07	OTTONE (nichelato/cromato) CHROMIUM-PLATED BRASS
08	PVC
09	DELIRIN
10	POLIPROPILENE - PP
11	PTFE + FV/GF

Cod.	Descr.
12	NYLON
13	ABS
14	AISI 430
15	AISI 430F
16	HOSTAFORM
17	HASTELLOY C
18	TITANIO - TITANIUM
19	INCOLOY 825
20	BRONZO - BRONZE
21	PVDF
22	POLIZENE
23	BYBLEND

**Materials code**

Cod.	Descr.
24	AISI 304L S.S.
25	INCONEL
26	SAF 2205
27	AISI 310 S.S.
28	AISI 420
29	AISI 904L
30	PP + TALCO - POWDER
31	AVP
33	POLIPROPILENE + F.V. PP + G.F.
36	PTFE
37	PFA

**Codici raccordi**

Cod.	Descr.	Cod.	Descr.
01	1/8"	15	5"
02	1/4"	17	6"
03	3/8"	18	36P 3
04	1/2"	19	11P1
05	3/4"	20	12P1
06	1"	21	13P1
07	1"1/4	22	12P1,25
08	1"1/2	23	10 P1
09	2"	24	28 P 1,337 (19FIL.)
10	2"1/2		
11	3"	25	17P1
13	4"	26	18P1

**Threads code**

Cod.	Descr.	Cod.	Descr.
27	19P1	93	M10
28	24P2	94	M6
29	21P2	95	5/16"
30	25P1	96	M5
50	M8 P0,75 BSPT	97	M8
70	3/8" UNF	98	10P0,75
71	5/8" UNF	99	8,075
72	19 P 1,5		
73	1/2 UNF		
90	20 P2		
92	M4		

Possibilità di personalizzare le marcature.  
Ability to customize the markings.



**SEZIONE 3 / SECTION 3****UGELLI ASSIALI E TANGENZIALI A CONO PIENO  
AXIAL AND TANGENTIAL FEED FULL-CONE NOZZLES**

INTRODUZIONE/INTRODUCTION		PAG. 39
SERIE/SERIES	OC	PAG. 40 - 46
SERIE/SERIES	OC2	PAG. 47
SERIE/SERIES	OCDF	PAG. 48
SERIE/SERIES	OCS	PAG. 49
SERIE/SERIES	OCQ	PAG. 50
SERIE/SERIES	OCLK	PAG. 51
SERIE/SERIES	OCLKF	PAG. 52
SERIE/SERIES	OCM	PAG. 53
SERIE/SERIES	OC - OCIR	PAG. 54 - 55
SERIE/SERIES	MF7	PAG. 56 - 57



Anche negli ugelli a cono pieno ad alimentazione assiale è indispensabile, per la formazione del getto, un diffusore con fresature inclinate, che imprime un movimento rotatorio al liquido e ne determina il frazionamento in gocce, prima dell'orifizio di uscita dell'ugello.

La proiezione del getto a cono pieno è una superficie che può essere circolare o quadrata e completamente riempita di liquido.

La distribuzione del getto è uniforme e le gocce sono di medie e grosse dimensioni. I nostri ugelli serie "OC" offrono una vasta gamma di portate anche molto elevate, alle quali si può ottenere una media forza di impatto del getto.



Also in the axial feed full-cone nozzles it is necessary, for forming the jet, a swirl-disc having raking millings, that gives an efficient rotation to the liquid and causes the splitting of it into droplets, before the outlet orifice of the nozzle.

The full-cone jet projection is a surface that can be circular or squared and fully filled in with liquid.

The jet distribution is uniform and the droplets have medium or big dimensions.

Our "OC" series nozzles offer

a wide range of flows, that can be very high too, at which you can have a medium jet impact force.





# UGELLI ASSIALI A CONO PIENO - SERIE OC AXIAL FEED FULL-CONE NOZZLES – OC SERIES

# OC



Tipo / Type OC x



Tipo / Type OC y

### CARATTERISTICHE

- Ricavato da barra esagonale
- Diffusore con fresature inclinate inserito all'interno del corpo
- Ampia gamma di portate
- Getto estremamente uniforme e ben distribuito
- Gocce di piccole e medie dimensioni

### APPLICAZIONI CONSIGLIATE

- Impianti di lavaggio materiali
- Raffreddamento materiali
- Abbattimento polveri
- Lavaggio e raffreddamento di gas e aria
- Abbattimento schiume
- Trattamenti chimici industriali
- Sistemi antincendio
- Cabine di verniciatura

### CHARACTERISTICS

- Made out of hexagonal bar
- Swirl-disc with raking millings, pressed inside the body
- Wide range of flows
- Particular uniform and well nebulized jet
- Small and medium-sized droplets

### TYPICAL APPLICATIONS

- Materials washing plants
- Materials cooling
- Dust suppression
- Air and gas washing and cooling
- Foam suppression
- Chemical-industrial treatments
- Fire-fighting systems
- Spray booth

CODE MAT.
02 AISI 316
04 AISI 303
06 Ottone/Brass
07 Ottone nichelato cromato /Chromium- plated brass
08 PVC
09 Delrin
10 Polipropilene/ Polypropylene
17 Hastelloy C
18 Titanio/Titanium
21 PVDF
22 Polizene
36 Teflon

## DATI OPERATIVI - OPERATIVE DATA

TIPO / TYPE OC x-y				CODICE PORTATA FLOW CODE	Ø E mm.	Ø U mm.	PORTATA / FLOW l/min										AMPIEZZA ANGOLO DI SPRUZZO SPRAY ANGLE WIDTH	
1/8"	1/4"	3/8"	1/2"				0,5 bar	1 bar	1,5 bar	2 bar	3 bar	4 bar	5 bar	7 bar	10 bar	15°	30°	
▼				047	0,8	0,6		0,36	0,42	0,47	0,55	0,62	0,68	0,78	0,89	●	●	
▼				059	0,9	0,6		0,45	0,53	0,59	0,69	0,78	0,85	0,97	1,12	●	●	
▼	▼			090	0,8	0,8		0,68	0,80	0,90	1,06	1,19	1,30	1,49	1,71	●	●	
▼	▼			101	1,4	1,2	0,63	0,83	0,98	1,1	1,3	1,5	1,6	1,8	2,1	●	●	
▼	▼			104	1,6	1,4	0,80	1,06	1,25	1,4	1,6	1,8	2,0	2,3	2,7	●	●	
	▼			106	1,7	1,5	0,92	1,2	1,4	1,6	1,9	2,1	2,3	2,6	3,0	●	●	
	▼			110	1,9	1,7	1,1	1,5	1,8	2,0	2,4	2,6	2,9	3,3	3,8	●	●	
	▼	▼		113	2,0	1,8	1,3	1,7	2,0	2,3	2,7	3,0	3,3	3,8	4,4	●	●	
	▼	▼		116	2,1	2,0	1,5	2,0	2,3	2,6	3,1	3,4	3,8	4,3	4,9	●	●	
	▼	▼		120	2,5	2,3	1,7	2,3	2,7	3,0	3,5	4,0	4,3	5,0	5,7	●	●	
	▼	▼		125	2,5	2,5	2,0	2,7	3,1	3,5	4,1	4,6	5,0	5,8	6,7	●	●	
		▼		130	2,8	2,7	2,3	3,0	3,6	4,0	4,7	5,3	5,8	6,6	7,6	●	●	
		▼		140	3,0	2,8	2,9	3,8	4,5	5,0	5,9	6,6	7,2	8,3	9,5	●	●	
		▼		150	3,5	3,0	3,4	4,5	5,3	6,0	7,1	7,9	8,7	9,9	11,4	●	●	
			▼	160	3,6	3,3	4,0	5,3	6,2	7,0	8,2	9,2	10,1	11,6	13,3	●	●	
			▼	175	4,0	3,5	4,9	6,4	7,6	8,5	10,0	11,2	12,3	14,0	16,2	●	●	
			▼	185	4,5	3,8	5,5	7,2	8,5	9,5	11,2	12,5	13,7	15,7	18,1	●	●	
			▼	215	4,8	4,2	7,2	9,5	11,1	12,5	14,7	16,5	18,0	21	24	●	●	
			▼	245	5,0	4,6	8,9	11,7	13,8	15,5	18,2	20	22	26	30	●	●	
			▼	260	5,5	5,0	9,8	12,9	15,2	17,0	20	22	25	28	32	●	●	
			▼	270	5,8	5,5	10,3	13,6	16,0	18,0	21	24	26	30	34	●	●	

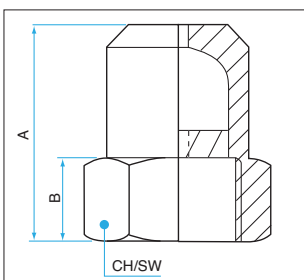

Tipo / Type OC x

DIMENSIONI DIMENSIONS	RACCORDO GAS CILINDRICO BSP BSP THREAD								RACCORDO MASCHIO GAS CONICO BSPT MALE BSPT THREAD			
	1/8"		1/4"		3/8"		1/2"		1/8"	1/4"	3/8"	1/2"
	x	y	x	y	x	y	x	y	y	y	y	y
A	24	16	27	18	35	25	40	30	16	18	25	30
B	8	8	8,5	8,5	10	10	12	12	8	8	10	12
CH/SW	13	13	17	17	22	22	24	24	13	14	17	22



# UGELLI ASSIALI A CONO PIENO - SERIE OC

## AXIAL FEED FULL-CONE NOZZLES – OC SERIES

**OC**

### DATI OPERATIVI - OPERATIVE DATA

TIPO / TYPE OC x-y				CODICE PORTATA FLOW CODE	PORTATA / FLOW l/min											AMPIEZZA ANGOLO DI SPRUZZO SPRAY ANGLE WIDTH	
1/8"	1/4"	3/8"	1/2"		Ø E mm.	Ø U mm.	0,5 bar	1 bar	1,5 bar	2 bar	3 bar	4 bar	5 bar	7 bar	10 bar	45°	60°
▼				047	0,6	0,8		0,36	0,42	0,47	0,55	0,62	0,68	0,78	0,89	●	●
▼				059	0,7	0,8		0,45	0,53	0,59	0,69	0,78	0,85	0,97	1,1	●	●
▼	▼	▼		090	1,0	1,0		0,68	0,80	0,90	1,1	1,2	1,3	1,5	1,7	●	●
▼	▼	▼		101	1,2	1,3	0,63	0,83	0,98	1,1	1,3	1,5	1,6	1,8	2,1	●	●
▼	▼	▼		104	1,4	1,5	0,80	1,1	1,2	1,4	1,6	1,8	2,0	2,3	2,7	●	●
▼	▼	▼		106	1,5	1,6	0,92	1,2	1,4	1,6	1,9	2,1	2,3	2,6	3,0	●	●
▼	▼	▼		110	1,7	2,0	1,1	1,5	1,8	2,0	2,4	2,6	2,9	3,3	3,8	●	●
▼	▼	▼		113	1,8	2,1	1,3	1,7	2,0	2,3	2,7	3,0	3,3	3,8	4,4	●	●
▼	▼	▼		116	1,9	2,2	1,5	2,0	2,3	2,6	3,1	3,4	3,8	4,3	4,9	●	●
▼	▼	▼		120	2,1	2,5	1,7	2,3	2,7	3,0	3,5	4,0	4,3	5,0	5,7	●	●
	▼	▼		125	2,3	2,6	2,0	2,7	3,1	3,5	4,1	4,6	5,0	5,8	6,7	●	●
	▼	▼		130	2,8	2,8	2,3	3,0	3,6	4,0	4,7	5,3	5,8	6,6	7,6	●	●
	▼	▼		140	2,9	3,0	2,9	3,8	4,5	5,0	5,9	6,6	7,2	8,3	9,5	●	●
		▼		150	3,5	3,7	3,4	4,5	5,3	6,0	7,1	7,9	8,7	9,9	11,4	●	●
		▼	▼	160	3,6	3,9	4,0	5,3	6,2	7,0	8,2	9,2	10,1	11,6	13,3	●	●
			▼	175	4,0	4,2	4,9	6,4	7,6	8,5	10,0	11,2	12,3	14,0	16,2	●	●
			▼	185	4,3	4,5	5,5	7,2	8,5	9,5	11,2	12,5	13,7	15,7	18,1	●	●
			▼	215	4,6	4,9	7,2	9,5	11,1	12,5	14,7	16,5	18,0	21	24	●	●
			▼	245	5,0	5,6	8,9	11,7	13,8	15,5	18,2	20	22	26	30	●	●
			▼	260	5,5	6,0	9,8	12,9	15,2	17	20	22	25	28	32	●	●
			▼	280	5,8	6,4	10,9	14,4	16,9	19	22	25	27	31	36	●	●
			▼	320	5,9	6,6	13,2	17,4	20	23	27	30	33	38	44	●	●

TIPO / TYPE OC x-y				CODICE PORTATA FLOW CODE	PORTATA / FLOW l/min											AMPIEZZA ANGOLO DI SPRUZZO SPRAY ANGLE WIDTH	
1/8"	1/4"	3/8"	1/2"		Ø E mm.	Ø U mm.	0,5 bar	1 bar	1,5 bar	2 bar	3 bar	4 bar	5 bar	7 bar	10 bar	90°	120°
▼				047	0,6	0,9		0,36	0,42	0,47	0,55	0,62	0,68	0,78	0,89	●	
▼				059	0,7	1,0		0,45	0,53	0,59	0,69	0,78	0,85	0,97	1,1	●	
▼	▼	▼		090	0,8	1,1		0,68	0,80	0,90	1,1	1,2	1,3	1,5	1,7	●	
▼	▼	▼		101	0,9	1,2	0,63	0,83	0,98	1,1	1,3	1,5	1,6	1,8	2,1	●	●
▼	▼	▼		104	1,0	1,3	0,80	1,1	1,2	1,4	1,6	1,8	2,0	2,3	2,7	●	●
▼	▼	▼		106	1,2	1,4	0,92	1,2	1,4	1,6	1,9	2,1	2,3	2,6	3,0	●	●
▼	▼	▼		110	1,5	1,7	1,1	1,5	1,8	2,0	2,4	2,6	2,9	3,3	3,8	●	●
▼	▼	▼		113	1,6	1,8	1,3	1,7	2,0	2,3	2,7	3,0	3,3	3,8	4,4	●	●
▼	▼	▼		116	1,7	2,2	1,5	2,0	2,3	2,6	3,1	3,4	3,8	4,3	4,9	●	●
▼	▼	▼		120	1,8	2,4	1,7	2,3	2,7	3,0	3,5	4,0	4,3	5,0	5,7	●	●
▼	▼	▼		125	1,9	2,6	2,0	2,7	3,1	3,5	4,1	4,6	5,0	5,8	6,7	●	●
	▼	▼		130	2,0	2,8	2,3	3,0	3,6	4,0	4,7	5,3	5,8	6,6	7,6	●	●
	▼	▼		140	2,1	2,9	2,9	3,8	4,5	5,0	5,9	6,6	7,2	8,3	9,5	●	●
	▼	▼		150	2,2	3,1	3,4	4,5	5,3	6,0	7,1	7,9	8,7	9,9	11,4	●	●
	▼	▼	▼	160	2,3	3,3	4,0	5,3	6,2	7,0	8,2	9,2	10,1	11,6	13,3	●	●
	▼	▼	▼	175	2,8	4,2	4,9	6,4	7,6	8,5	10,0	11,2	12,3	14,0	16,2	●	●
		▼	▼	185	3,1	4,5	5,5	7,2	8,5	9,5	11,2	12,5	13,7	15,7	18,1	●	●
		▼	▼	215	3,6	5,3	7,2	9,5	11,1	12,5	14,7	16,5	18,0	21	24	●	●
			▼	245	3,9	5,8	8,9	11,7	13,8	15,5	18,2	20	22	26	30	●	●
			▼	260	4,3	6,5	9,8	12,9	15,2	17	20	22	25	28	32	●	●
			▼	280	4,8	7,0	10,9	14,4	16,9	19	22	25	27	31	36	●	●
			▼	320	5,1	7,6	13,2	17,4	20	23	27	30	33	38	44	●	●
			▼	350	5,3	8,1	14,9	19,7	23	26	31	34	38	43	49	●	●
			▼	380	5,6	8,8	16,7	22	26	29	34	38	42	48	55	●	●
			▼	400	6,1	9,3	17,8	23	28	31	36	41	45	51	59	●	●

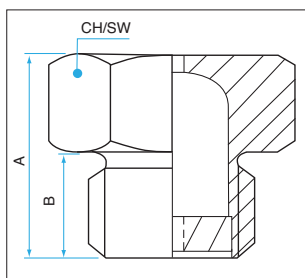

Tipo / Type OC y

DIMENSIONI DIMENSIONS	RACCORDO GAS CILINDRICO BSP BSP THREAD								RACCORDO MASCHIO GAS CONICO BSPT MALE BSPT THREAD			
	1/8"		1/4"		3/8"		1/2"		1/8"	1/4"	3/8"	1/2"
	x	y	x	y	x	y	x	y	y	y	y	y
A	20	13	22	14	30	20	35	25	16	18	17	25
B	8	4	8,5	8,5	10	10	12	12	8	8	10	12
CH/SW	13	13	17	17	22	22	24	24	13	14	19	22





# UGELLI ASSIALI A CONO PIENO - SERIE OC

## AXIAL FEED FULL-CONE NOZZLES – OC SERIES

# OC



Tipo / Type OC x



Tipo / Type OC y

### CARATTERISTICHE

- Ricavato da barra esagonale
- Diffusore con fresature inclinate inserito all'interno del corpo
- Ampia gamma di portate
- Getto estremamente uniforme e ben distribuito
- Gocce di medie dimensioni

### APPLICAZIONI CONSIGLIATE

- Impianti di lavaggio materiali
- Raffreddamento materiali
- Abbattimento polveri
- Lavaggio e raffreddamento di gas e aria
- Abbattimento schiume
- Trattamenti chimici industriali
- Sistemi antincendio
- Cabine di verniciatura

### CHARACTERISTICS

- Made out of hexagonal bar
- Swirl-disc with raking millings, pressed inside the body
- Wide range of flow
- Particular uniform and well nebulized jet
- Medium-sized droplets

### TYPICAL APPLICATIONS

- Materials washing plants
- Materials cooling
- Dust suppression
- Air and gas washing and cooling
- Foam suppression
- Chemical-industrial treatments
- Fire-fighting systems
- Spray booth

CODE MAT.
02 AISI 316
04 AISI 303
06 Ottone/Brass
07 Ottone nichelato cromato /Chromium-plated brass
08 PVC
09 Delrin
10 Polipropilene/ Polypropylene
17 Hastelloy C
18 Titanio/Titanium
21 PVDF
22 Polizene
36 Teflon

## DATI OPERATIVI - OPERATIVE DATA

TIPO OC - Dimensione raccordo OC TYPE - Thread dimension				CODICE PORTATA FLOW CODE	Ø E mm.	Ø U mm.	PORTATA / FLOW l/min										AMPIEZZA ANGOLO DI SPRUZZO SPRAY ANGLE WIDTH	
3/4"	1"	1"1/4	1"1/2				0,5 bar	1 bar	1,5 bar	2 bar	3 bar	4 bar	5 bar	7 bar	10 bar	15°	30°	
▼				240	5,0	4,6	8,6	11,4	13,4	15	17,6	20	22	25	29	●	●	
▼				260	5,5	5,0	9,8	12,9	15,2	17	20	22	25	28	32	●	●	
▼				270	5,8	5,5	10,3	13,6	16,0	18	21	24	26	30	34	●	●	
▼				320	5,9	5,9	13,2	17,4	20	23	27	30	33	38	44	●	●	
▼				350	6,1	6,4	14,9	19,7	23	26	31	34	38	43	49	●	●	
	▼			380	6,4	6,6	16,7	22	26	29	34	38	42	48	55	●	●	
	▼			400	6,6	6,7	17,8	23	28	31	36	41	45	51	59	●	●	
	▼			410	7,3	7,0	21	27	32	36	42	48	52	59	69	●	●	
	▼			418	7,3	7,4	23	30	36	40	47	53	58	66	76	●	●	
		▼		422	7,6	7,6	24	32	37	42	49	55	61	69	80	●	●	
		▼		436	7,9	8,0	28	37	44	49	58	65	71	81	93	●	●	
		▼		466	8,8	8,5	36	48	56	63	74	83	91	104	120	●	●	
		▼		482	8,8	8,8	41	54	63	71	84	94	102	117	135	●	●	
			▼	514	9,5	9,4	50	66	78	87	102	115	126	144	166	●	●	
			▼	542	11,2	11,0	59	77	91	102	120	135	147	168	194	●	●	
			▼	576	11,5	11,5	67	89	104	117	138	154	169	193	223	●	●	

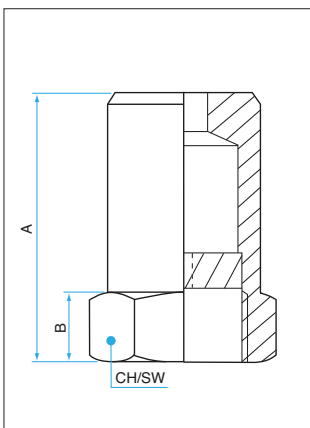

Tipo / Type OC x

DIMENSIONI DIMENSIONS	RACCORDO GAS CILINDRICO BSP BSP THREAD								RACCORDO MASCHIO GAS CONICO BSPT MALE BSPT THREAD			
	3/4"		1"		1" 1/4		1" 1/2		3/4"	1"	1" 1/4	1" 1/2
	x	y	x	y	x	y	x	y	y	y	y	y
A	50	45	65	50	80	65	90	70	45	50	65	70
B	14	14	16	16	19	19	19	19	14	16	19	19
CH/SW	30	30	36	36	45	45	50	50	30	36	45	50



# UGELLI ASSIALI A CONO PIENO - SERIE OC

## AXIAL FEED FULL-CONE NOZZLES – OC SERIES

**OC**

### DATI OPERATIVI - OPERATIVE DATA

TIPO OC - Dimensione raccordo OC TYPE - Thread dimension				CODICE PORTATA FLOW CODE	Ø E mm.	Ø U mm.	PORTATA / FLOW l/min										AMPIEZZA ANGOLO DI SPRUZZO SPRAY ANGLE WIDTH	
3/4"	1"	1"1/4	1"1/2				0,5 bar	1 bar	1,5 bar	2 bar	3 bar	4 bar	5 bar	7 bar	10 bar	45°	60°	
▼				240	4,8	4,8	8,6	11,4	13,4	15	17,6	20	22	25	29	●	●	
▼				260	5,3	5,2	9,8	12,9	15,2	17	20	22	25	28	32	●	●	
▼				270	5,6	5,7	10,3	13,6	16,0	18	21	24	26	30	34	●	●	
▼				320	5,7	6,1	13,2	17,4	20	23	27	30	33	38	44	●	●	
▼				350	5,9	6,6	14,9	19,7	23	26	31	34	38	43	49	●	●	
▼	▼			380	6,2	6,8	16,7	22	26	29	34	38	42	48	55	●	●	
▼	▼			400	6,4	6,9	17,8	23	28	31	36	41	45	51	59	●	●	
▼	▼			410	7,1	7,2	21	27	32	36	42	48	52	59	69	●	●	
	▼			418	7,3	7,6	23	30	36	40	47	53	58	66	76	●	●	
	▼			422	7,4	7,8	24	32	37	42	49	55	61	69	80	●	●	
	▼	▼		436	7,7	8,2	28	37	44	49	58	65	71	81	93	●	●	
		▼		466	8,6	8,7	36	48	56	63	74	83	91	104	120	●	●	
		▼		482	8,8	9,2	41	54	63	71	84	94	102	117	135	●	●	
		▼	▼	514	9,3	9,6	50	66	78	87	102	115	126	144	166	●	●	
			▼	542	11,0	11,2	59	77	91	102	120	135	147	168	194	●	●	
			▼	576	11,3	11,6	67	89	104	117	138	154	169	193	223	●	●	
			▼	622	11,8	12,4	82	108	127	142	167	187	205	234	270	●	●	
			▼	632	12,0	12,8	87	115	135	152	179	201	219	251	289	●	●	
			▼	650	12,3	13,6	98	129	152	170	200	224	245	281	324	●	●	
			▼	681	12,5	13,2	115	152	179	201	236	265	290	332	383	●	●	

TIPO OC - Dimensione raccordo OC TYPE - Thread dimension				CODICE PORTATA FLOW CODE	Ø E mm.	Ø U mm.	PORTATA / FLOW l/min										AMPIEZZA ANGOLO DI SPRUZZO SPRAY ANGLE WIDTH	
Raccordo maschio / Male connection							0,5 bar	1 bar	1,5 bar	2 bar	3 bar	4 bar	5 bar	7 bar	10 bar	90°	120°	
3/4"	1"	1"1/4	1"1/2															
▼				240	4,5	5,5	8,6	11,4	13,4	15	17,6	20	22	25	29	●	●	
▼				260	5,0	5,7	9,8	12,9	15,2	17	20	22	25	28	32	●	●	
▼				270	5,2	6,0	10,3	13,6	16,0	18	21	24	26	30	34	●	●	
▼				320	5,5	6,3	13,2	17,4	20	23	27	30	33	38	44	●	●	
▼				350	5,7	7,0	14,9	20	23	26	31	34	38	43	49	●	●	
▼	▼			380	6,0	7,2	16,7	22	26	29	34	38	42	48	55	●	●	
▼	▼			400	6,2	7,4	17,8	23	28	31	36	41	45	51	59	●	●	
▼	▼			410	6,5	7,5	21	27	32	36	42	48	52	59	69	●	●	
▼	▼			418	6,7	8,0	23	30	36	40	47	53	58	66	76	●	●	
▼	▼			422	7,0	8,5	24	32	37	42	49	55	61	69	80	●	●	
▼	▼	▼		436	7,2	8,8	28	37	44	49	58	65	71	81	93	●	●	
	▼	▼		466	8,0	9,5	36	48	56	63	74	83	91	104	120	●	●	
	▼	▼		482	8,5	10,0	41	54	63	71	84	94	102	117	135	●	●	
	▼	▼	▼	514	8,8	10,5	50	66	78	87	102	115	126	144	166	●	●	
		▼	▼	542	9,3	11,5	59	77	91	102	120	135	147	168	194	●	●	
		▼	▼	576	10,5	12,5	67	89	104	117	138	154	169	193	223	●	●	
		▼	▼	622	11,0	13,5	82	108	127	142	167	187	205	234	270	●	●	
		▼	▼	632	11,5	14,0	87	115	135	152	179	201	219	251	289	●	●	
		▼	▼	650	12,0	15,0	98	129	152	170	200	224	245	281	324	●	●	
		▼	▼	681	12,5	16,0	115	152	179	201	236	265	290	332	383	●	●	
		▼	▼	692	13,0	17,0	122	161	189	212	249	280	306	350	404	●	●	

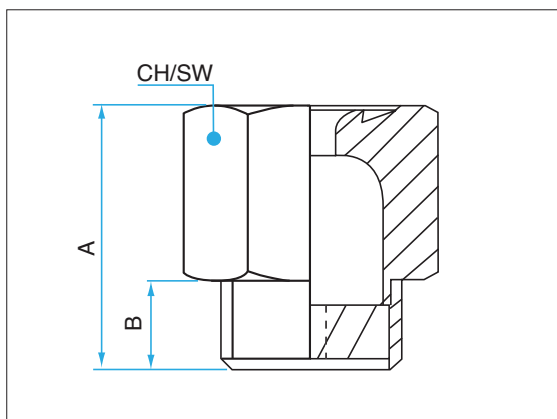

Tipo / Type OC y

DIMENSIONI DIMENSIONS	RACCORDO GAS CILINDRICO BSP BSP THREAD								RACCORDO MASCHIO GAS CONICO BSPT MALE BSPT THREAD			
	3/4"		1"		1" 1/4		1" 1/2		3/4"	1"	1" 1/4	1" 1/2
	x	y	x	y	x	y	x	y	y	y	y	y
A	45	30	50	35	65	50	75	55	30	35	50	55
B	14	14	16	16	19	19	19	19	14	16	19	19
CH/SW	30	30	36	36	45	45	50	50	30	36	45	50



# UGELLI ASSIALI A CONO PIENO - SERIE OC

## AXIAL FEED FULL-CONE NOZZLES – OC SERIES

# OC



Tipo / Type OC x



Tipo / Type OC y

### CARATTERISTICHE

- Ricavato da barra esagonale
- Diffusore con fresature inclinate inserito all'interno del corpo
- Ampia gamma di portate
- Getto estremamente uniforme e ben distribuito
- Gocce di grandi dimensioni

### APPLICAZIONI CONSIGLIATE

- Impianti di lavaggio materiali
- Raffreddamento materiali
- Abbattimento polveri
- Lavaggio e raffreddamento di gas e aria
- Abbattimento schiume
- Trattamenti chimici industriali
- Sistemi antincendio
- Cabine di verniciatura

### CHARACTERISTICS

- Made out of hexagonal bar
- Swirl-disc with raking millings, pressed inside the body
- Wide range of flows
- Particular uniform and well nebulized jet
- Big-sized droplets

### TYPICAL APPLICATIONS

- Materials washing plants
- Materials cooling
- Dust suppression
- Air and gas washing and cooling
- Foam suppression
- Chemical-industrial treatments
- Fire-fighting systems
- Spray booth

CODE MAT.
02 AISI 316
04 AISI 303
06 Ottone/Brass
07 Ottone nichelato cromato /Chromium-plated brass
08 PVC
09 Delrin
10 Polipropilene / Polypropylene
17 Hastelloy C
18 Titanio/Titanium
21 PVDF
22 Polizene
36 Teflon

## DATI OPERATIVI - OPERATIVE DATA

TIPO OC - Dimensione raccordo OC TYPE - Thread dimension			CODICE PORTATA FLOW CODE	PORTATA / FLOW l/min											AMPIEZZA ANGOLO DI SPRUZZO SPRAY ANGLE WIDTH
2"	2"1/2	3"		Ø E mm.	Ø U mm.	0,5 bar	1 bar	1,5 bar	2 bar	3 bar	4 bar	5 bar	7 bar	10 bar	30°
▼			576	12,0	11,5	67	89	104	117	138	154	169	193	223	●
▼			622	13,0	12,5	82	108	127	142	167	187	205	234	270	●
▼			632	13,5	13,0	87	115	135	152	179	201	219	251	289	●
▼			650	14,5	13,5	98	129	152	170	200	224	245	281	324	●
	▼		681	16,0	14,5	115	152	179	201	236	265	290	332	383	●
	▼		692	16,5	15,0	122	161	189	212	249	280	306	350	404	●
	▼		700	16,5	15,5	126	167	196	220	259	290	317	363	419	●
	▼		733	17,5	16,0	145	192	225	253	298	334	365	418	482	●
		▼	775	18,5	17,0	169	224	263	295	347	389	426	487	562	●
		▼	820	20,0	18,5	207	273	321	360	423	475	519	594	685	●
		▼	842	22,0	20,0	247	326	383	430	506	567	620	710	819	●
		▼	862	23,0	21,0	296	390	459	515	606	680	743	850	980	●
		▼	878	25,0	23,0	342	451	530	595	700	785	858	982	1133	●

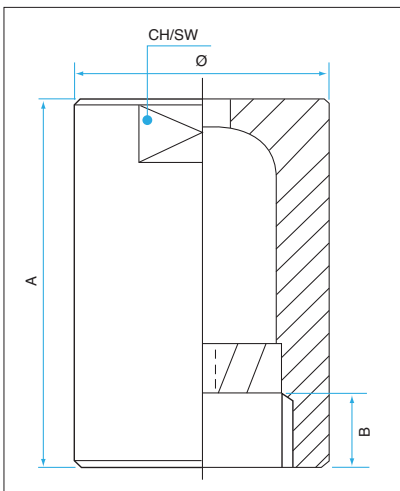

Tipo / Type OC x

DIMENSIONI DIMENSIONS	RACCORDO GAS CILINDRICO BSP BSP THREAD					
	2"		2" 1/2		3"	
	x	y	x	y	x	y
A	120	100	140	120	150	130
B	20	20	25	25	30	30
Ø	70	60	90	80	100	90
CH/SW	60	50	80	70	90	80

# UGELLI ASSIALI A CONO PIENO - SERIE OC

## AXIAL FEED FULL-CONE NOZZLES – OC SERIES

**OC**

### DATI OPERATIVI - OPERATIVE DATA

TIPO OC - Dimensione raccordo OC TYPE - Thread dimension			CODICE PORTATA FLOW CODE	Ø E mm.	Ø U mm.	PORTATA / FLOW l/min										AMPIEZZA ANGOLO DI SPRUZZO SPRAY ANGLE WIDTH	
2"	2"1/2	3"				0,5 bar	1 bar	1,5 bar	2 bar	3 bar	4 bar	5 bar	7 bar	10 bar	45°	60°	
▼			576	11,0	13,0	67	89	104	117	138	154	169	193	223	●	●	
▼			622	12,0	13,5	82	108	127	142	167	187	205	234	270	●	●	
▼	▼		632	13,5	14,0	87	115	135	152	179	201	219	251	289	●	●	
▼	▼		650	13,5	14,5	98	129	152	170	200	224	245	281	324	●	●	
▼	▼		681	14,0	16,5	115	152	179	201	236	265	290	332	383	●	●	
▼	▼		692	14,5	17,0	122	161	189	212	249	280	306	350	404	●	●	
▼	▼		700	15,0	17,0	126	167	196	220	259	290	317	363	419	●	●	
▼	▼		733	15,5	18,0	145	192	225	253	298	334	365	418	482	●	●	
▼	▼	▼	775	16,5	19,0	169	224	263	295	347	389	426	487	562	●	●	
	▼	▼	820	19,0	21,0	207	273	321	360	423	475	519	594	685	●	●	
	▼	▼	842	20,0	22,0	247	326	383	430	506	567	620	710	819	●	●	
	▼	▼	862	21,0	23,0	296	390	459	515	606	680	743	850	980	●	●	
		▼	878	23,0	25,0	342	451	530	595	700	785	858	982	1133	●	●	
		▼	890	26,0	30,0	373	493	579	650	764	858	938	1073	1237	●	●	
		▼	909	28,0	31,0	425	561	660	740	870	976	1068	1221	1409	●	●	

### DATI OPERATIVI - OPERATIVE DATA

TIPO OC - Dimensione raccordo OC TYPE - Thread dimension			CODICE PORTATA FLOW CODE	Ø E mm.	Ø U mm.	PORTATA / FLOW l/min										AMPIEZZA ANGOLO DI SPRUZZO SPRAY ANGLE WIDTH	
2"	2"1/2	3"				0,5 bar	1 bar	1,5 bar	2 bar	3 bar	4 bar	5 bar	7 bar	10 bar	90°	120°	
▼			576	10,0	14,0	67	89	104	117	138	154	169	193	223	●	●	
▼			622	11,0	14,5	82	108	127	142	167	187	205	234	270	●	●	
▼	▼		632	12,5	15,0	87	115	135	152	179	201	219	251	289	●	●	
▼	▼		650	12,5	15,5	98	129	152	170	200	224	245	281	324	●	●	
▼	▼		681	13,0	17,5	115	152	179	201	236	265	290	332	383	●	●	
▼	▼		692	13,5	18,0	122	161	189	212	249	280	306	350	404	●	●	
▼	▼		700	14,0	18,0	126	167	196	220	259	290	317	363	419	●	●	
▼	▼		733	14,5	19,0	145	192	225	253	298	334	365	418	482	●	●	
▼	▼	▼	775	17,5	20,0	169	224	263	295	347	389	426	487	562	●	●	
	▼	▼	820	20,0	22,0	207	273	321	360	423	475	519	594	685	●	●	
	▼	▼	842	21,0	23,0	247	326	383	430	506	567	620	710	819	●	●	
	▼	▼	862	22,0	24,0	296	390	459	515	606	680	743	850	980	●	●	
		▼	878	24,0	26,0	342	451	530	595	700	785	858	982	1133	●	●	
		▼	890	27,0	31,0	373	493	579	650	764	858	938	1073	1237	●	●	
		▼	909	29,0	32,0	425	561	660	740	870	976	1068	1221	1409	●	●	

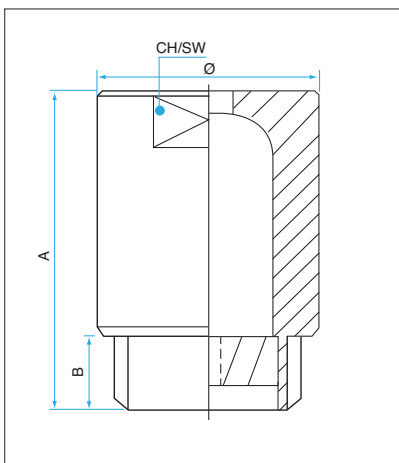

Tipo / Type OC y

DIMENSIONI DIMENSIONS	RACCORDO GAS CILINDRICO BSP BSP THREAD					
	2"		2" 1/2		3"	
	x	y	x	y	x	y
A	100	80	110	90	130	110
B	20	20	25	25	30	30
Ø	70	60	90	80	100	90
CH/SW	60	50	80	70	90	80





# UGELLI ASSIALI A CONO PIENO - SERIE OC

## AXIAL FEED FULL-CONE NOZZLES – OC SERIES

# OC



Tipo / Type OC x



Tipo / Type OC y

### CARATTERISTICHE

- Ricavato da barra
- Diffusore con fresature inclinate inserito all'interno del corpo
- Ampia gamma di portate
- Getto estremamente uniforme e ben distribuito
- Gocce di grandi dimensioni

### APPLICAZIONI CONSIGLIATE

- Impianti di lavaggio materiali
- Raffreddamento materiali
- Abbattimento polveri
- Lavaggio e raffreddamento di gas e aria
- Abbattimento schiume
- Trattamenti chimici industriali
- Sistemi antincendio
- Cabine di verniciatura

### CHARACTERISTICS

- Made out of bar
- Swirl-disc with raking millings, pressed inside the body
- Wide range of flows
- Particular uniform and well nebulized jet
- Big-sized droplets

### TYPICAL APPLICATIONS

- Materials washing plants
- Materials cooling
- Dust suppression
- Air and gas washing and cooling
- Foam suppression
- Chemical-industrial treatments
- Fire-fighting systems
- Spray booth

CODE MAT.
02 AISI 316
04 AISI 303
06 Ottone/Brass
07 Ottone nichelato cromato /Chromium-plated brass
08 PVC
09 Delrin
10 Polipropilene / Polypropylene
17 Hastelloy C
18 Titanio/Titanium
21 PVDF
22 Polizene
36 Teflon

## DATI OPERATIVI - OPERATIVE DATA

TIPO OC - Dimensione raccordo OC TYPE - Thread dimension			CODICE PORTATA FLOW CODE	PORTATA / FLOW l/min										AMPIEZZA ANGOLO DI SPRUZZO SPRAY ANGLE WIDTH		
4"	5"	6"		Ø E mm.	Ø U mm.	0,5 bar	1 bar	1,5 bar	2 bar	3 bar	4 bar	5 bar	7 bar	10 bar	90°	120°
▼			941	19,0	42,0	632	834	980	1100	1294	1451	1587	1816	2094	●	●
▼			944	21,0	45,0	689	909	1070	1200	1411	1583	1731	1981	2284	●	●
▼			946	23,0	48,0	747	985	1159	1300	1529	1715	1876	2146	2475	●	●
▼			948	25,0	51,0	804	1061	1248	1400	1647	1847	2020	2311	2665	●	●
▼			950	27,0	54,0	862	1137	1337	1500	1764	1979	2164	2476	2855	●	●
	▼		959	30,0	52,0	1034	1364	1604	1800	2117	2375	2597	2971	3427	●	●
	▼		960	33,0	55,0	1149	1516	1783	2000	2352	2639	2885	3301	3807	●	●
	▼		965	36,0	60,0	1264	1667	1961	2200	2587	2903	3174	3631	4188	●	●
	▼		968	39,0	65,0	1378	1819	2139	2400	2823	3167	3462	3961	4569	●	●
		▼	970	40,0	68,0	1436	1895	2228	2500	2940	3299	3607	4126	4759	●	●
		▼	976	42,0	70,0	1608	2122	2496	2800	3293	3695	4040	4622	5330	●	●
		▼	982	42,0	72,0	1780	2349	2763	3100	3646	4090	4472	5117	5901	●	●
		▼	987	44,0	74,0	1953	2577	3030	3400	3999	4486	4905	5612	6472	●	●
		▼	992	46,0	76,0	2125	2804	3298	3700	4351	4882	5338	6107	7044	●	●
		▼	995	46,0	78,0	2297	3031	3565	4000	4704	5278	5771	6602	7615	●	●

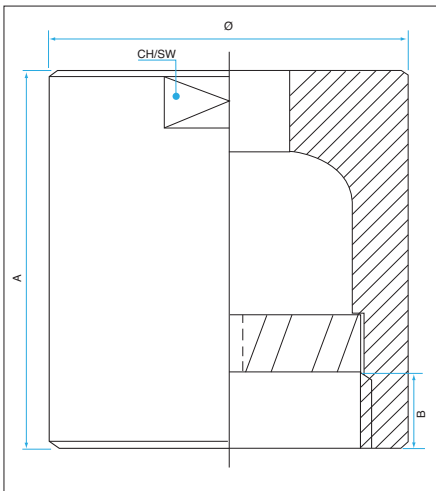

Tipo / Type OC x

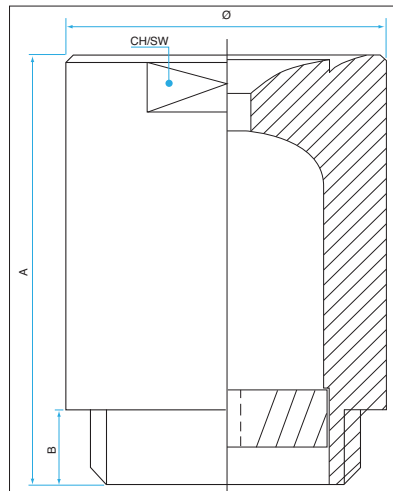

Tipo / Type OC y

DIMENSIONI DIMENSIONS	RACCORDO GAS CILINDRICO BSP BSP THREAD					
	4"		5"		6"	
	x	y	x	y	x	y
A	150	130	180	160	200	180
B	35	35	40	40	40	40
Ø	130	120	150	140	190	170
CH/SW	100	100	120	120	120	150



# UGELLI ASSIALI A CONO PIENO - SERIE OC2

## AXIAL FEED FULL-CONE NOZZLES – OC2 SERIES

# OC



Tipo / Type OC2 y

### CARATTERISTICHE

- Ricavato da barra
- Diffusore a disco con fresature radiali inclinate rimovibile
- Costruzione in 2 pezzi
- Possibilità di inserimento filtro
- Gocce di media grandezza

### APPLICAZIONI CONSIGLIATE

- Impianti di lavaggio materiali
- Raffreddamento materiali
- Abbattimento polveri
- Lavaggio e raffreddamento di gas e aria
- Abbattimento schiume
- Trattamenti chimici industriali
- Sistemi antincendio
- Cabine di verniciatura

### CHARACTERISTICS

- Made out of bar
- Removable swirl-disc with raking radial millings
- Manufactured in 2 pieces
- Equipped, on request, with strain
- Medium-sized droplets

### TYPICAL APPLICATIONS

- Materials washing plants
- Materials cooling
- Dust suppression
- Air and gas washing and cooling
- Foam suppression
- Chemical-industrial treatments
- Fire-fighting system
- Spray booth

CODE STD. MAT.
02 AISI 316
04 AISI 303
06 Ottone/Brass
07 Ottone nichelato cromato /Chromium-plated brass
08 PVC
10 Polipropilene/Polypropylene

CODE NOT STD. MAT.
9 Delrin
17 Hastelloy c
18 Titanio
21 PVDF
22 Polizene
36 Teflon

## DATI OPERATIVI - OPERATIVE DATA

TIPO / TYPE OC2 y Dimensione raccordo Thread dimension			CODICE PORTATA FLOW CODE	PORTATA / FLOW l/min											AMPIEZZA ANGOLO DI SPRUZZO SPRAY ANGLE WIDTH			
1/8"	1/4"	3/8"		Ø E mm.	Ø U mm.	0,5 bar	1 bar	1,5 bar	2 bar	3 bar	4 bar	5 bar	7 bar	10 bar	45°	60°	90°	120°
▼			047	0,6	0,8		0,36	0,42	0,47	0,55	0,62	0,68	0,78	0,89	●	●		
▼			059	0,7	0,8		0,45	0,53	0,59	0,69	0,78	0,85	0,97	1,1	●	●		
▼			090	1,0	1,0		0,68	0,80	0,90	1,1	1,2	1,3	1,5	1,7	●	●	●	
▼			101	1,2	1,3	0,63	0,83	0,98	1,1	1,3	1,5	1,6	1,8	2,1	●	●	●	
▼			104	1,4	1,5	0,80	1,1	1,2	1,4	1,6	1,8	2,0	2,3	2,7	●	●	●	
▼			106	1,5	1,6	0,92	1,2	1,4	1,6	1,9	2,1	2,3	2,6	3,0	●	●	●	●
▼			110	1,7	2,0	1,1	1,5	1,8	2,0	2,4	2,6	2,9	3,3	3,8	●	●	●	●
▼			113	1,8	2,1	1,3	1,7	2,0	2,3	2,7	3,0	3,3	3,8	4,4	●	●	●	●
	▼	▼	116	1,9	2,2	1,5	2,0	2,3	2,6	3,1	3,4	3,8	4,3	4,9	●	●	●	●
	▼	▼	120	2,1	2,5	1,7	2,3	2,7	3,0	3,5	4,0	4,3	5,0	5,7	●	●	●	●
	▼	▼	125	2,3	2,6	2,0	2,7	3,1	3,5	4,1	4,6	5,0	5,8	6,7	●	●	●	●
	▼	▼	130	2,8	2,8	2,3	3,0	3,6	4,0	4,7	5,3	5,8	6,6	7,6	●	●	●	●
	▼	▼	140	2,9	3,0	2,9	3,8	4,5	5,0	5,9	6,6	7,2	8,3	9,5	●	●	●	●
	▼	▼	150	3,5	3,7	3,4	4,5	5,3	6,0	7,1	7,9	8,7	9,9	11,4	●	●	●	●
	▼	▼	160	3,6	3,9	4,0	5,3	6,2	7,0	8,2	9,2	10,1	11,6	13,3	●	●	●	●
		▼	175	4,0	4,2	4,9	6,4	7,6	8,5	10,0	11,2	12,3	14,0	16,2	●	●	●	●
		▼	185	4,3	4,5	5,5	7,2	8,5	9,5	11,2	12,5	13,7	15,7	18,1	●	●	●	●
		▼	215	4,6	4,9	7,2	9,5	11,1	12,5	14,7	16,5	18,0	21	24	●	●	●	●
		▼	245	5,0	5,6	8,9	11,7	13,8	15,5	18,2	20	22	26	30	●	●	●	●
		▼	260	5,5	6,0	9,8	12,9	15,2	17	20	22	25	28	32	●	●	●	●
		▼	280	5,8	6,4	10,9	14,4	16,9	19	22	25	27	31	36	●	●	●	●
		▼	320	5,9	6,6	13,2	17,4	20	23	27	30	33	38	44	●	●	●	●

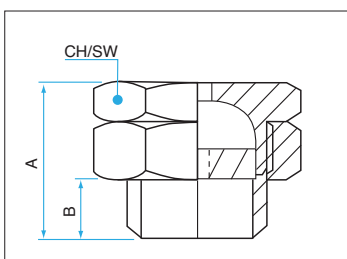

Tipo / Type OC2 y

DIMENSIONI DIMENSIONS	RACCORDO GAS BSP/BSPT BSP/BSPT THREAD ANGOLO / ANGLE 45° - 120°			RACCORDO GAS BSP/BSPT BSP/BSPT THREAD ANGOLO / ANGLE 60° - 90°		
	1/8" y	1/4" y	3/8" y	1/8" y	1/4" y	3/8" y
A	24	27	27 - 24	22	22	22 - 24
B	9	8	9	9	8	9
CH/SW	17	22	22	17	22	22

# UGELLI ASSIALI A CONO PIENO - SERIE OCDF - Montaggio a parete

## AXIAL FEED FULL-CONE NOZZLES – OCDF SERIES - Wall-mounting

# OC



Tipo / Type OCDF y



Tipo / Type OCDF x

### CARATTERISTICHE

- Ricavato da barra
- Diffusore a disco con fresature radiali inclinate
- Doppio filetto per montaggio a parete
- Gocce di media grandezza

### APPLICAZIONI CONSIGLIATE

- Impianti di lavaggio materiali
- Raffreddamento materiali
- Abbattimento polveri
- Lavaggio e raffreddamento di gas e aria
- Abbattimento schiume
- Trattamenti chimici industriali
- Sistemi antincendio
- Cabine di verniciatura

### CHARACTERISTICS

- Made out of bar
- Swirl-disc with raking radial millings
- Double thread for wall-mounting
- Medium-sized droplets

### TYPICAL APPLICATIONS

- Materials washing plants
- Materials cooling
- Dust suppression
- Air and gas washing and cooling
- Foam suppression
- Chemical-industrial treatments
- Fire-fighting systems
- Spray booth

### CODE STD. MAT.

- 02 AISI 316
- 04 AISI 303
- 06 Ottone/Brass
- 07 Ottone nichelato cromato /Chromium-plated brass
- 08 PVC
- 10 Polipropilene / Polypropylene

### CODE NOT STD. MAT.

- 9 Delrin
- 17 Hastelloy c
- 18 Titanio
- 21 PVDF
- 22 Polizene
- 36 Teflon

## DATI OPERATIVI - OPERATIVE DATA

TIPO / TYPE OCDF x-y Dimensione raccordo Thread dimension				CODICE PORTATA FLOW CODE	PORTATA / FLOW l/min											AMPIEZZA ANGOLO DI SPRUZZO SPRAY ANGLE WIDTH			
1/8"	1/4"	3/8"	1/2"		Ø E mm.	Ø U mm.	0,5 bar	1 bar	1,5 bar	2 bar	3 bar	4 bar	5 bar	7 bar	10 bar	45°	60°	90°	120°
▼				047	0,6	0,8		0,36	0,42	0,47	0,55	0,62	0,68	0,78	0,89	●	●		
▼				059	0,7	0,8		0,45	0,53	0,59	0,69	0,78	0,85	0,97	1,1	●	●		
▼				090	1,0	1,0		0,68	0,80	0,90	1,1	1,2	1,3	1,5	1,7	●	●	●	
▼				101	1,2	1,3	0,63	0,83	0,98	1,1	1,3	1,5	1,6	1,8	2,1	●	●	●	
▼				104	1,4	1,5	0,80	1,1	1,2	1,4	1,6	1,8	2,0	2,3	2,7	●	●	●	
▼				106	1,5	1,6	0,92	1,2	1,4	1,6	1,9	2,1	2,3	2,6	3,0	●	●	●	●
▼				110	1,7	2,0	1,1	1,5	1,8	2,0	2,4	2,6	2,9	3,3	3,8	●	●	●	●
▼				113	1,8	2,1	1,3	1,7	2,0	2,3	2,7	3,0	3,3	3,8	4,4	●	●	●	●
	▼			116	1,9	2,2	1,5	2,0	2,3	2,6	3,1	3,4	3,8	4,3	4,9	●	●	●	●
	▼			120	2,1	2,5	1,7	2,3	2,7	3,0	3,5	4,0	4,3	5,0	5,7	●	●	●	●
	▼			125	2,3	2,6	2,0	2,7	3,1	3,5	4,1	4,6	5,0	5,8	6,7	●	●	●	●
	▼			130	2,8	2,8	2,3	3,0	3,6	4,0	4,7	5,3	5,8	6,6	7,6	●	●	●	●
	▼	▼		140	2,9	3,0	2,9	3,8	4,5	5,0	5,9	6,6	7,2	8,3	9,5	●	●	●	●
	▼	▼		150	3,5	3,7	3,4	4,5	5,3	6,0	7,1	7,9	8,7	9,9	11,4	●	●	●	●
	▼	▼		160	3,6	3,9	4,0	5,3	6,2	7,0	8,2	9,2	10,1	11,6	13,3	●	●	●	●
		▼	▼	175	4,0	4,2	4,9	6,4	7,6	8,5	10,0	11,2	12,3	14,0	16	●	●	●	●
		▼	▼	185	4,3	4,5	5,5	7,2	8,5	9,5	11,2	12,5	13,7	15,7	18	●	●	●	●
		▼	▼	215	4,6	4,9	7,2	9,5	11,1	12,5	14,7	16	18	21	24	●	●	●	●
			▼	245	5,0	5,6	8,9	11,7	13,8	15,5	18	20	22	26	30	●	●	●	●
			▼	260	5,5	6,0	9,8	12,9	15,2	17	20	22	25	28	32		●	●	●
			▼	280	5,8	6,4	10,9	14,4	16	19	22	25	27	31	36		●	●	●
			▼	320	5,9	6,6	13,2	17	20	23	27	30	33	38	44		●	●	●

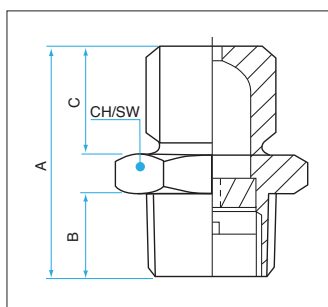

Tipo / Type OCDF - y

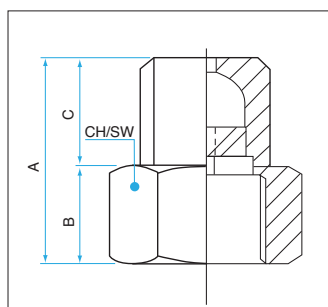

Tipo / Type OCDF - x

DIMENSIONI DIMENSIONS	RACCORDO GAS CILINDRICO BSP BSP THREAD			
	1/8" x - y	1/4" x - y	3/8" x - y	1/2" x - y
A	20	23	30	38
B	8	8	10	12
C	7	10	15	21
CH/SW	13	17	22	24

# UGELLI ASSIALI A CONO PIENO - SERIE OCS - Getto orientabile

## AXIAL FEED FULL-CONE NOZZLES – OCS SERIES - Revolving jet

**OC**



Tipo / Type OCS y

### CARATTERISTICHE

- Ricavato da barra
- Diffusore a disco con fresature radiali inclinate
- Sfera ugello orientabile
- Gocce di media grandezza
- Materiali non standard a richiesta

### APPLICAZIONI CONSIGLIATE

- Impianti di lavaggio materiali
- Raffreddamento materiali
- Abbattimento polveri
- Lavaggio e raffreddamento di gas e aria
- Abbattimento schiume
- Trattamenti chimici industriali
- Sistemi antincendio
- Cabine di verniciatura

### CHARACTERISTICS

- Made out of bar
- Swirl-disc with raking radial millings
- Revolving ball-nozzles
- Medium-sized droplets
- Not standard materials on request

### TYPICAL APPLICATIONS

- Materials washing plants
- Materials cooling
- Dust suppression
- Air and gas washing and cooling
- Foam suppression
- Chemical-industrial treatments
- Fire-fighting systems
- Spray booth

CODE STD.

MAT.

02 AISI 316  
06 Ottone/Brass  
08 PVC

## DATI OPERATIVI - OPERATIVE DATA

TIPO / TYPE OCS - y Dimensione raccordo Thread dimension						CODICE PORTATA FLOW CODE	Ø E mm.	Ø U mm.	PORTATA / FLOW l/min										AMPIEZZA ANGOLO DI SPRUZZO SPRAY ANGLE WIDTH		
1/8"	1/4"	3/8"	1/2"	3/4"	1"				0,5 bar	1 bar	1,5 bar	2 bar	3 bar	4 bar	5 bar	7 bar	10 bar	45°	60°	90°	
▼	▼	▼	▼			047	0,6	0,8		0,36	0,42	0,47	0,55	0,62	0,68	0,78	0,89	●	●		
▼	▼	▼	▼			059	0,7	0,8		0,45	0,53	0,59	0,69	0,78	0,85	0,97	1,1	●	●		
▼	▼	▼	▼			090	1,0	1,0		0,68	0,80	0,90	1,1	1,2	1,3	1,5	1,7	●	●		
▼	▼	▼	▼			101	1,2	1,3	0,63	0,83	0,98	1,1	1,3	1,5	1,6	1,8	2,1	●	●	●	
▼	▼	▼	▼			104	1,4	1,5	0,80	1,1	1,2	1,4	1,6	1,8	2,0	2,3	2,7	●	●	●	
▼	▼	▼	▼			106	1,5	1,6	0,92	1,2	1,4	1,6	1,9	2,1	2,3	2,6	3,0	●	●	●	
▼	▼	▼	▼			110	1,7	2,0	1,1	1,5	1,8	2,0	2,4	2,6	2,9	3,3	3,8	●	●	●	
▼	▼	▼	▼			113	1,8	2,1	1,3	1,7	2,0	2,3	2,7	3,0	3,3	3,8	4,4	●	●	●	
	▼	▼	▼			116	1,9	2,2	1,5	2,0	2,3	2,6	3,1	3,4	3,8	4,3	4,9	●	●	●	
	▼	▼	▼			120	2,1	2,5	1,7	2,3	2,7	3,0	3,5	4,0	4,3	5,0	5,7	●	●	●	
	▼	▼	▼			125	2,3	2,6	2,0	2,7	3,1	3,5	4,1	4,6	5,0	5,8	6,7	●	●	●	
	▼	▼	▼			130	2,8	2,8	2,3	3,0	3,6	4,0	4,7	5,3	5,8	6,6	7,6	●	●	●	
	▼	▼	▼			140	2,9	3,0	2,9	3,8	4,5	5,0	5,9	6,6	7,2	8,3	9,5	●	●	●	
	▼	▼	▼			150	3,5	3,7	3,4	4,5	5,3	6,0	7,1	7,9	8,7	9,9	11,4	●	●	●	
	▼	▼	▼			160	3,6	3,9	4,0	5,3	6,2	7,0	8,2	9,2	10,1	11,6	13,3	●	●	●	
		▼	▼			175	4,0	4,2	4,9	6,4	7,6	8,5	10,0	11,2	12,3	14,0	16,2	●	●	●	
		▼	▼			185	4,3	4,5	5,5	7,2	8,5	9,5	11,2	12,5	13,7	15,7	18	●	●	●	
		▼	▼			215	4,6	4,9	7,2	9,5	11,1	12,5	14,7	16,5	18	21	24	●	●	●	
			▼			245	5,0	5,6	8,9	11,7	13,8	15,5	18,2	20	22	26	30	●	●	●	
			▼	▼		260	5,5	6,0	9,8	12,9	15,2	17	20	22	25	28	32	●	●	●	
			▼	▼	▼	280	5,8	6,4	10,9	14,4	16,9	19	22	25	27	31	36	●	●	●	
			▼	▼	▼	320	5,9	6,6	13,2	17,4	20	23	27	30	33	38	44	●	●	●	
			▼	▼	▼	350	5,9	6,6	14,9	19,7	23	26	31	34	38	43	49	●	●	●	
			▼	▼	▼	380	5,9	6,6	16,7	22	26	29	34	38	42	48	55	●	●	●	
			▼	▼	▼	400	5,9	6,6	17,8	23	28	31	36	41	45	51	59	●	●	●	
			▼	▼	▼	410	5,9	6,6	21	27	32	36	42	48	52	59	69	●	●	●	
			▼	▼	▼	418	5,9	6,6	23	30	36	40	47	53	58	66	76	●	●	●	

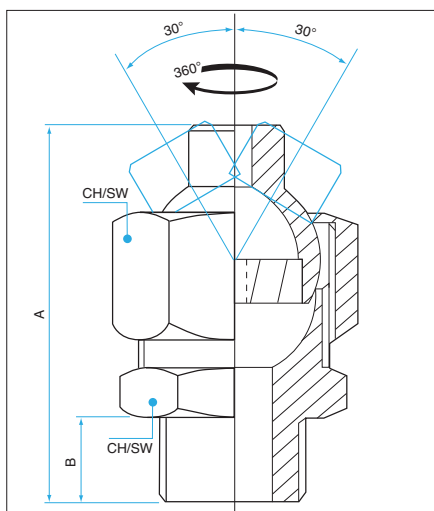

Tipo / Type OCS y

DIMENSIONI DIMENSIONS	RACCORDO MASCHIO GAS CILINDRICO BSP MALE BSP THREAD					
	1/8" y	1/4" y	3/8" y	1/2" y	3/4" y	1" y
A	42	42	42	42	55	55
B	10	10	10	10	13	13
CH/SW	22/24	22/24	22/24	22/24	36	36



# UGELLI ASSIALI A CONO PIENO - SERIE OCQ - Getto a sezione quadrata

## AXIAL FEED FULL-CONE NOZZLES - OCQ SERIES - Square jet

# OC



Tipo / Type OCQ y 120°

### CARATTERISTICHE

- Ricavato da barra
- Diffusore a disco con fresature radiali inclinate
- Getto a sezione quadrata
- Gocce di media grandezza
- Materiali non standard a richiesta

### CHARACTERISTICS

- Made out of bar
- Swirl-disc with raking radial millings
- Square-jet
- Medium-sized droplets
- Not standard materials on request

CODE STD. MAT.
02 AISI 316
04 AISI 303
06 Ottone/Brass
07 Ottone nichelato cromato /Chromium-plated brass
08 PVC
10 Polipropilene / Polypropylene

### APPLICAZIONI CONSIGLIATE

- Impianti di lavaggio materiali
- Raffreddamento materiali
- Abbattimento polveri
- Lavaggio e raffreddamento di gas e aria
- Abbattimento schiume
- Trattamenti chimici industriali
- Sistemi antincendio
- Cabine di verniciatura

### TYPICAL APPLICATIONS

- Materials washing plants
- Materials cooling
- Dust suppression
- Air and gas washing and cooling
- Foam suppression
- Chemical-industrial treatments
- Fire-fighting system
- Spray booth



Tipo / Type OCQ y 60°/90°

## DATI OPERATIVI - OPERATIVE DATA

TIPO / TYPE OCQ y Dimensione raccordo Thread dimension					CODICE PORTATA FLOW CODE	PORTATA / FLOW l/min										AMPIEZZA ANGOLO DI SPRUZZO SPRAY ANGLE WIDTH			
1/8"	1/4"	3/8"	1/2"	3/4"		Ø E mm.	Ø U mm.	0,5 bar	1 bar	1,5 bar	2 bar	3 bar	4 bar	5 bar	7 bar	10 bar	60°	90°	120°
▼					116	1,7	2,2	1,5	2,0	2,3	2,6	3,1	3,4	3,8	4,3	4,9	●	●	●
▼					120	1,8	2,4	1,7	2,3	2,7	3,0	3,5	4,0	4,3	5,0	5,7	●	●	●
▼					125	1,9	2,6	2,0	2,7	3,1	3,5	4,1	4,6	5,0	5,8	6,7	●	●	●
▼					130	2,0	2,8	2,3	3,0	3,6	4,0	4,7	5,3	5,8	6,6	7,6	●	●	●
	▼				140	2,1	2,9	2,9	3,8	4,5	5,0	5,9	6,6	7,2	8,3	9,5	●	●	●
	▼				150	2,2	3,1	3,4	4,5	5,3	6,0	7,1	7,9	8,7	9,9	11,4	●	●	●
	▼	▼			160	2,3	3,3	4,0	5,3	6,2	7,0	8,2	9,2	10,1	11,6	13,3	●	●	●
	▼	▼	▼		175	2,8	4,2	4,9	6,4	7,6	8,5	10,0	11,2	12,3	14,0	16,2	●	●	●
		▼	▼		185	3,1	4,5	5,5	7,2	8,5	9,5	11,2	12,5	13,7	15,7	18	●	●	●
		▼	▼	▼	215	3,6	5,3	7,2	9,5	11,1	12,5	14,7	16,5	18	21	24	●	●	●
		▼	▼	▼	245	3,9	5,8	8,9	11,7	13,8	15,5	18	20	22	26	30	●	●	●
			▼	▼	260	4,3	6,5	9,8	12,9	15,2	17	20	22	25	28	32	●	●	●
			▼	▼	280	4,8	7,0	10,9	14,4	16,9	19	22	25	27	31	36	●	●	●
			▼	▼	320	5,1	7,6	13,2	17,4	20	23	27	30	33	38	44	●	●	●
			▼	▼	350	5,3	8,1	14,9	19,7	23	26	31	34	38	43	49	●	●	●
			▼	▼	380	5,6	8,8	16,7	22	26	29	34	38	42	48	55	●	●	●
			▼	▼	400	6,1	9,3	17,8	23	28	31	36	41	45	51	59	●	●	●

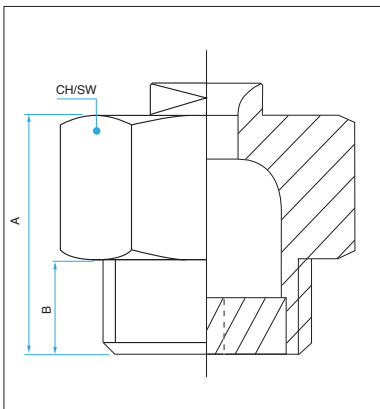

Tipo / Type OCQ y 120°

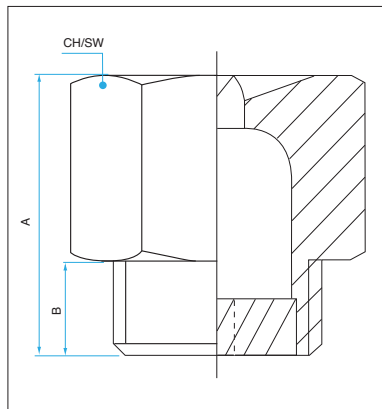

Tipo / Type OCQ y 60°/90°

DIMENSIONI DIMENSIONS	RACCORDO MASCHIO GAS CILINDRICO BSP MALE BSP THREAD				
	1/8"	1/4"	3/8"	1/2"	3/4"
A	16	18	20	25	35
B	8	8	10	12	12
CH/SW	13	14	22	22	30/32