



**UGELLI
ASSIALI E TANGENZIALI
A GETTO PIATTO
AXIAL AND TANGENTIAL-FEED
VEE AND FLAT JET NOZZLES**



Sezioni

Il catalogo è suddiviso in sezioni contraddistinte da colori diversi, ogni colore identifica un particolare tipo di getto.

All'inizio di ogni sezione, una serie di informazioni tecniche potrà aiutarvi ad individuare il tipo di ugello più adatto alle vostre esigenze.

GETTO A CONO VUOTO	GETTO A CONO VUOTO TANGENZIALE	GETTO A CONO PIENO	GETTO PIATTO E GETTO RETTILINEO	GETTO ATOMIZZATO	ACCESSORI
HOLLOW-CONE JET	TANGENTIAL FEED HOLLOW-CONE JET	FULL-CONE JET	VEE-JET AND RECTILINEAR JET	ATOMIZED-JET	ACCESSORIES

Sections

For your easy reference we have divided our brochure into sections, marked by different colours, every colour identifies a particular shape of jet.

At the beginning of every section you will find the technical information, that will assist you in choosing the correct nozzle design for your applications.

Dimensione orifizi

Le dimensioni degli orifizi sono espresse in mm e i valori indicati sono nominali.

Orifices dimensions

The dimensions of the orifices are indicated in mm and the values are nominal.

Raccordo filettato

Tutti gli ugelli sono forniti con raccordo standard GAS CILINDRICO (BSP) o GAS CONICO (BSPT).
Filettature NPT o altre a richiesta.

Threaded connection

All our nozzles have standard PARALLEL GAS thread (BSP) or CONICAL GAS thread (BSPT).
NPT thread or other thread on request.

Legenda

- Ø E = Massimo diametro di passaggio libero, affinché le particelle sospese nel liquido non intasino l'ugello.
- Ø U = Diametro nominale dell'orifizio.
- Ø O = Diametro nominale equivalente.
- X = Raccordo filettato femmina.
- Y = Raccordo filettato maschio.

Key

- Ø E = The maximum diameter of free passage, so that the solid particles in the sprayed liquid do not clog the nozzle.
- Ø U = The nominal diameter of the orifice.
- Ø O = The equivalent nominal diameter.
- X = Female thread connection.
- Y = Male thread connection.

Tabelle dati operativi

Le tabelle delle portate riportano nella colonna evidenziata in azzurro la portata rilevata alla pressione di 2 bar, che è la pressione di riferimento in fase di collaudo del prodotto. Le portate relative a pressioni differenti esposte nelle tabelle sono il risultato di un calcolo matematico. A richiesta è possibile collaudare gli ugelli a pressioni differenti (da 0,5 a 100 bar).

Operative data tables

The flows tables report on the blue column the flow measured at 2 bar, that is the datum flow during the production tests. Flow values at different pressures have been calculated. We can test our nozzles at different pressure (from 0,5 to 100 bar) on request.

DATI OPERATIVI - OPERATIVE DATA

TIPO OCy - Dimensione raccordo OCy TYPE - Thread dimension				CODICE PORTATA FLOW CODE	PORTATA / FLOW l/min										
3/4"	1"	1"1/4	1"1/2		Ø E mm.	Ø U mm.	0,5 bar	1 bar	1,5 bar	2 bar	3 bar	4 bar	5 bar	7 bar	10 bar
▼				240	5,0	4,6	8,6	11,4	13,4	15	17,6	20	22	25	29
▼				260	5,5	5,0	9,8	12,9	15,2	17	20	22	25	28	32
▼				270	5,8	5,5	10,3	13,6	16,0	18	21	24	26	30	34
				320	5,0	5,0	10,0	12,5	15,0	17,5	20,0	22,5	25,0	27,5	30,0



È facile ordinare

Dalle tabelle è possibile recuperare tutti i dati necessari per l'ordinazione.

Ecco un esempio di come ordinare un ugello a cono pieno serie OC, raccordo maschio da 2" 1/2, portata 152 l/min., pressione 2 bar, angolo 90°, materiale AISI 316 (vedi pag 45):

It's easy to pass an order

You can find on the flow tables all data to pass an order. For example you want to order a full-cone nozzle OC serie, male connection, 2" 1/2 thd., flow 152 l/min., pressure 2 bar, spray angle 90°, material AISI 316 (see page 45):

OC y 2" 1/2 632 90° AISI 316

DATI OPERATIVI - OPERATIVE DATA

TIPO OCx-y - Dimensione raccordo OCx-y TYPE - Thread dimension			CODICE PORTATA FLOW CODE	PORTATA / FLOW l/min											AMPIEZZA ANGOLO DI SPRUZZO SPRAY ANGLE WIDTH	
2"	2"1/2	3"		Ø E mm.	Ø U mm.	0,5 bar	1 bar	1,5 bar	2 bar	3 bar	4 bar	5 bar	7 bar	10 bar	90°	120°
▼			576	10,0	14,0	67	89	104	117	138	154	169	193	223	●	●
▼			622	11,0	14,5	82	108	127	142	167	187	205	234	270	●	●
▼	▼		632	12,5	15,0	87	115	135	152	179	201	219	251	289	●	●
▼			650	12,5	15,5	98	125	145	170	200	224	245	284	330	●	●

Codici materiali

Cod.	Descr.
01	FERRO - CARBON STEEL
02	AISI 316 S.S.
03	AISI 316L S.S.
04	AISI 303 S.S.
05	AISI 304 S.S.
06	OTTONE - BRASS
07	OTTONE (nichelato/cromato) CHROMIUM-PLATED BRASS
08	PVC
09	DELIRIN
10	POLIPROPILENE - PP
11	PTFE + FV/GF

Cod.	Descr.
12	NYLON
13	ABS
14	AISI 430
15	AISI 430F
16	HOSTAFORM
17	HASTELLOY C
18	TITANIO - TITANIUM
19	INCOLOY 825
20	BRONZO - BRONZE
21	PVDF
22	POLIZENE
23	BYBLEND

Materials code

Cod.	Descr.
24	AISI 304L S.S.
25	INCONEL
26	SAF 2205
27	AISI 310 S.S.
28	AISI 420
29	AISI 904L
30	PP + TALCO - POWDER
31	AVP
33	POLIPROPILENE + F.V. PP + G.F.
36	PTFE
37	PFA

Codici raccordi

Cod.	Descr.	Cod.	Descr.
01	1/8"	15	5"
02	1/4"	17	6"
03	3/8"	18	36P 3
04	1/2"	19	11P1
05	3/4"	20	12P1
06	1"	21	13P1
07	1"1/4	22	12P1,25
08	1"1/2	23	10 P1
09	2"	24	28 P 1,337 (19FIL.)
10	2"1/2		
11	3"	25	17P1
13	4"	26	18P1

Threads code

Cod.	Descr.	Cod.	Descr.
27	19P1	93	M10
28	24P2	94	M6
29	21P2	95	5/16"
30	25P1	96	M5
50	M8 P0,75 BSPT	97	M8
70	3/8" UNF	98	10P0,75
71	5/8" UNF	99	8,075
72	19 P 1,5		
73	1/2 UNF		
90	20 P2		
92	M4		

Possibilità di personalizzare le marcature.
Ability to customize the markings.



SEZIONE 4 / SECTION 4**UGELLI ASSIALI E TANGENZIALI A GETTO PIATTO
AXIAL AND TANGENTIAL FEED, VEE AND FLAT JET NOZZLES**

INTRODUZIONE/INTRODUCTION		PAG. 59
SERIE/SERIES	OV	PAG. 60 - 64
SERIE/SERIES	OV1	PAG. 65 - 66
SERIE/SERIES	OVK - OVKIR	PAG. 67
SERIE/SERIES	OVS	PAG. 68
SERIE/SERIES	OVSU	PAG. 69
SERIE/SERIES	OVSU-IR	PAG. 70
SERIE/SERIES	OVIR	PAG. 71
SERIE/SERIES	A/V	PAG. 72
SERIE/SERIES	PV	PAG. 73
SERIE/SERIES	PVT	PAG. 74 - 75
SERIE/SERIES	OL	PAG. 76 - 77
SERIE/SERIES	OLL /OLT/OLTI	PAG. 78 - 79
SERIE/SERIES	OLP	PAG. 80 - 81
SERIE/SERIES	GR	PAG. 82 - 83
SERIE/SERIES	F3	PAG. 84 - 85



UGELLI ASSIALI E TANGENZIALI A GETTO PIATTO- SERIE OV / PV / OL / GR / F3 AXIAL AND TANGENTIAL FEED VEE AND FLAT/JET NOZZLES - OV / PV / OL / GR / F3 SERIES

Negli ugelli a getto piatto il liquido si fraziona all'esterno dell'ugello prima in lamelle e, solo successivamente, si ha la formazione di gocce di piccole e medie dimensioni.

Il getto piatto così ottenuto ha la forma di un ventaglio. Questo tipo di getto viene realizzato praticando un orificio ellittico oppure un orificio circolare tangente ad una superficie di deflessione.



In vee-jet nozzles the liquid is splitted outside the nozzles at first into blades, and only later, you have the formation of small and medium-sized droplets.

The above vee-jet is fan-shaped. This type of jet is made by means of an elliptical orifice or a circular orifice that is tangential to a surface of deflection (flat-jet).

Negli ugelli serie "OV" e "PV" con orificio ellittico il getto è perpendicolare all'asse di alimentazione del liquido e la sua proiezione è un'ellisse con le estremità rastremate. In questo caso sovrapponendo i getti si può ottenere con l'uso di più ugelli adiacenti una copertura uniforme della superficie da trattare.

In "OV" and "PV" series nozzles, having elliptical orifice, the jet is perpendicular to the axis of feed of the liquid and the jet projection is an ellipse with tapered ends. In this case you can obtain an uniform covering of the surface to treat, by overlapping the jets and using several adjacent nozzles.

Negli ugelli serie "OL" con orificio circolare il getto ha estremità ben definite e devia rispetto all'asse di entrata del liquido, con un'inclinazione che va dai 75° ai 90°.

I nostri ugelli a getto piatto offrono una vasta gamma di portate ed angoli di spruzzo.

Il getto è ben nebulizzato e sviluppa una media forza d'impatto che raggiunge i massimi livelli con angoli di spruzzo stretti (5° - 15°).

In the "OL" series nozzles, having circular orifices, the jet has well delineated ends and diverts in respect of the inlet axis of liquid according to an angle of downwash from 75° to 90°

Our vee-jet nozzles offer a wide range of flows and spray angles.

The jet is well atomized and creates a medium impact force, that can reach the maximum levels with narrow spray angles (5° - 15°).

These features make our vee-jet nozzles specially suitable for washing and cooling plants in iron and steel industries and above all, for surface treatment plants, where an high impact force of the jet is requested.

Tali caratteristiche rendono i nostri ugelli a getto piatto particolarmente indicati per gli impianti di lavaggio e raffreddamento nell'industria siderurgica e soprattutto, per gli impianti di trattamento delle superfici, dove è richiesta un'elevata forza di impatto del getto.

Per queste applicazioni sono stati appositamente studiati alcuni accessori (attacchi rapidi a fascetta, nippoli a coda di rondine e snodi orientabili), che rendono più rapido ed economico il montaggio degli ugelli sugli impianti.



For above applications we have specially studied some fittings (quick clamp connectors, dove-tail nipples and revolving ball-joints), that make the mounting of nozzles onto plants quicker and cheaper.

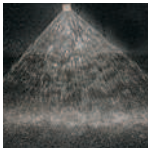

UGELLI ASSIALI A GETTO PIATTO - SERIE OV

AXIAL-FEED VEE-JET NOZZLES – OV SERIES

OV

CARATTERISTICHE

- Ricavati da barra e lavorati di precisione
- Ampia gamma di portate ed angoli di spruzzo
- Getto ben nebulizzato
- Gocce di piccola e media grandezza
- Elevata forza d'impatto
- La proiezione del getto ha estremità rastremate

CHARACTERISTICS

- Made out of bar and precision machined
- Wide range of flows and spray angles
- Well nebulized jet
- Small and medium-sized droplets
- High impact force
- The jet projection has tapered ends

CODE STD. MAT.

- 02 AISI 316
- 04 AISI 303
- 06 Ottone/Brass
- 07 Ottone nichelato cromato /Chromium-plated brass
- 08 PVC
- 09 Delrin
- 10 Polipropilene/ Polypropylene

APPLICAZIONI CONSIGLIATE

- Lavaggio e raffreddamento materiali
- Trattamento delle superfici
- Lavaggio filtri
- Lavaggio nastri
- Raffreddamento serbatoi
- Controllo polveri
- Sistemi antincendio
- Lavatrici e lavastoviglie industriali
- Vasche galvaniche
- Industria siderurgica tessile e cartaria

TYPICAL APPLICATIONS

- Materials washing and cooling
- Surface treatment
- Filter washing
- Band washing
- Tanks cooling
- Dust control
- Fire fighting systems
- Industrial washing and dishwashing machines
- Galvanic bath tanks
- Iron and steel industries
- Paper factories
- Textile industries

DATI OPERATIVI - OPERATIVE DATA

TIPO / TYPE OV Dimensione raccordo Thread dimension		CODICE PORTATA FLOW CODE	PORTATA / FLOW l/min									AMPIEZZA ANGOLO DI SPRUZZO SPRAY ANGLE WIDTH					
1/8"	1/4"		0,5 bar	1 bar	1,5 bar	2 bar	3 bar	4 bar	5 bar	7 bar	10 bar	15 bar	25°	45°	60°	90°	120°
▼		034		0,24	0,29	0,34	0,42	0,48	0,54	0,64	0,76	0,93	●	●	●	●	
▼		041		0,29	0,36	0,41	0,50	0,58	0,65	0,77	0,92	1,12	●	●	●	●	
▼		047		0,33	0,41	0,47	0,58	0,66	0,74	0,88	1,1	1,3	●	●	●	●	
▼		061	0,31	0,43	0,53	0,61	0,75	0,86	0,96	1,1	1,4	1,7	●	●	●	●	
▼		080	0,40	0,57	0,69	0,80	0,98	1,1	1,3	1,5	1,8	2,2	●	●	●	●	
▼	▼	100	0,50	0,71	0,87	1,0	1,2	1,4	1,6	1,9	2,2	2,7	●	●	●	●	●
▼	▼	104	0,70	0,99	1,2	1,4	1,7	2,0	2,2	2,6	3,1	3,8	●	●	●	●	●
▼	▼	110	1,00	1,4	1,7	2,0	2,4	2,8	3,2	3,7	4,5	5,5	●	●	●	●	●
▼	▼	116	1,3	1,8	2,3	2,6	3,2	3,7	4,1	4,9	5,8	7,1	●	●	●	●	●
▼	▼	122	1,6	2,3	2,8	3,2	3,9	4,5	5,1	6,0	7,2	8,8	●	●	●	●	●
▼	▼	128	1,9	2,7	3,3	3,8	4,7	5,4	6,0	7,1	8,5	10,4	●	●	●	●	●
▼	▼	136	2,3	3,3	4,0	4,6	5,6	6,5	7,3	8,6	10,3	12,6	●	●	●	●	●
▼	▼	144	2,7	3,8	4,7	5,4	6,6	7,6	8,5	10,1	12,1	15	●	●	●	●	●
▼	▼	153	3,2	4,5	5,5	6,3	7,7	8,9	10,0	11,8	14	17	●	●	●	●	●
▼	▼	170	4,0	5,7	6,9	8,0	9,8	11,3	12,6	15	18	22	●	●	●	●	●
▼	▼	175	4,3	6,0	7,4	8,5	10,4	12,0	13	16	19	23	●	●	●	●	●
	▼	185	4,8	6,7	8,2	9,5	11,6	13	15	18	21	26	●	●	●	●	●
	▼	205	5,8	8,1	10,0	11,5	14	16	18	22	26	31	●	●	●	●	●
	▼	215	6,3	8,8	10,8	12,5	15	18	20	23	28	34	●	●	●	●	●
	▼	240	7,3	10,3	13	15	18	21	23	27	32	40	●	●	●	●	●
	▼	250	8,0	11,3	14	16	20	23	25	30	36	44	●	●	●	●	●
	▼	260	8,5	12,0	15	17	21	24	27	32	38	47	●	●	●	●	●
	▼	270	9,0	13	16	18	22	25	28	34	40	49	●	●	●	●	●
	▼	280	9,5	13	16	19	23	27	30	36	42	52	●	●	●	●	●
	▼	290	10,0	14	17	20	24	28	32	37	45	55	●	●	●	●	●
	▼	300	10,5	15	18	21	26	30	33	39	47	58	●	●	●	●	●
	▼	310	11,0	16	19	22	27	31	35	41	49	60	●	●	●	●	●
	▼	320	11,5	16	20	23	28	33	36	43	51	63	●	●	●	●	●
	▼	331	12,0	17	21	24	29	34	38	45	54	66	●	●	●	●	●
	▼	340	12,5	18	22	25	31	35	40	47	56	68	●	●	●	●	●
	▼	350	13	18	23	26	32	37	41	49	58	71	●	●	●	●	●
	▼	360	14	19	23	27	33	38	43	51	60	74	●	●	●	●	●



UGELLI ASSIALI A GETTO PIATTO - SERIE OV AXIAL-FEED VEE-JET NOZZLES – OV SERIES

OV

VASTA GAMMA DI DIMENSIONI PER OGNI ESIGENZA DI INSTALLAZIONE

WIDE RANGE OF DIMENSIONS FOR ANY KIND OF MOUNTING NEED

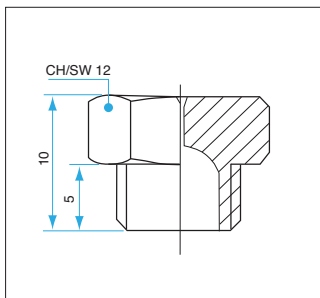

Tipo / Type OV y 1/8" M. BSP
CH/SW 12x10

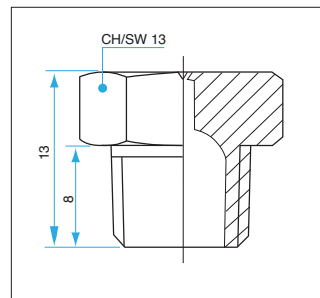

Tipo / Type OV y 1/8" M. BSPT
CH/SW 13x13

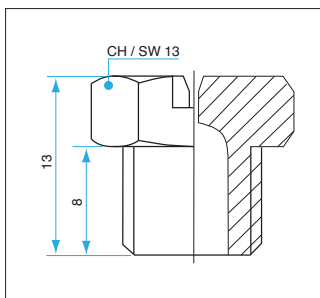

Tipo / Type OV y 1/8" M. BSPT
CH/SW 13x13 - ANGOLO/ANGLE >90°

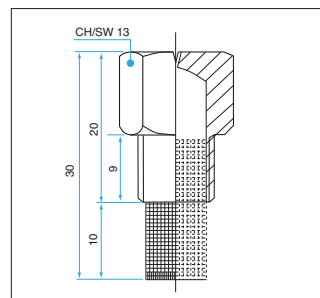

Tipo / Type OV y 1/8" M. BSP
CH/SW 13x20 - CON FILTRO/WITH STRAIN

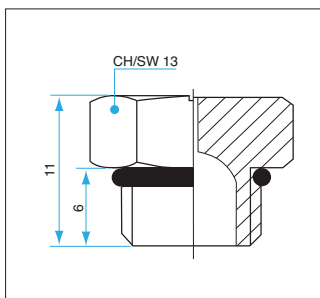

Tipo / Type OV y 1/8" M. BSP
CH/SW 13x11

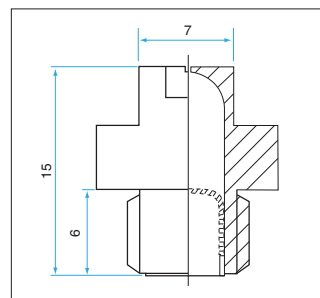

Tipo / Type OV y 1/8" M. BSP
Ø 13,5x15

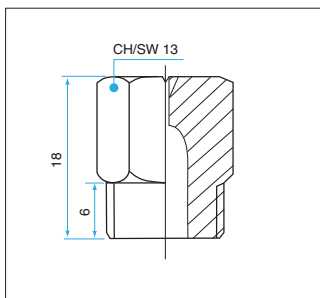

Tipo / Type OV y 1/4" M. BSP
CH/SW 13x18

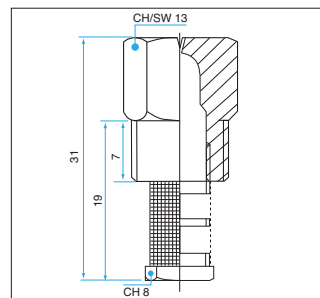

Tipo / Type OV y 1/4" M. BSP
CH/SW 13x18 - CON FILTRO/WITH STRAIN

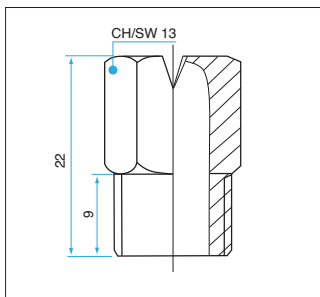

Tipo / Type OV y 1/4" M. BSP
CH/SW 13x22

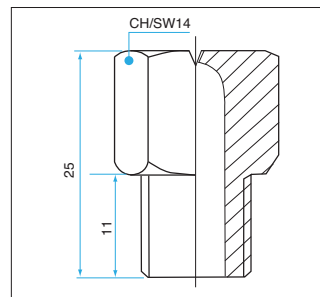

Tipo / Type OV y 1/4" M. BSPT
CH/SW 14x25

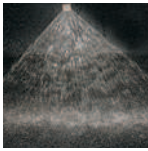

UGELLI ASSIALI A GETTO PIATTO - SERIE OV

AXIAL-FEED VEE-JET NOZZLES – OV SERIES

OV



Tipo / Type OV y 3/8"



Tipo / Type OV y 1/2" NPT



Tipo / Type OV y 1/2"

CARATTERISTICHE

- Ricavati da barra esagonale e lavorati di precisione
- Ampia gamma di portate ed angoli di spruzzo
- Getto ben nebulizzato
- Gocce di piccola e media grandezza
- Elevata forza d'impatto
- La proiezione del getto ha estremità rastremate

CHARACTERISTICS

- Made out of hexagonal bar and precision machined
- Wide range of flows and spray angles
- Well nebulized jet
- Small and medium-sized droplets
- High impact force
- The jet projection has tapered ends

CODE STD. MAT.

02 AISI 316
04 AISI 303
06 Ottone/Brass
07 Ottone nichelato cromato /Chromium-plated brass
08 PVC
09 Delrin
10 Polipropilene/Polypropylene

APPLICAZIONI CONSIGLIATE

- Lavaggio e raffreddamento materiali
- Trattamento delle superfici
- Lavaggio filtri
- Lavaggio nastri
- Raffreddamento serbatoi
- Controllo polveri
- Sistemi antincendio
- Lavatrici e lavastoviglie industriali
- Vasche galvaniche
- Industria siderurgica tessile e cartaria

TYPICAL APPLICATIONS

- Materials washing and cooling
- Surface treatment
- Filter washing
- Band washing
- Tanks cooling
- Dust control
- Fire fighting systems
- Industrial washing and dishwashing machines
- Galvanic bath tanks
- Iron and steel industries
- Paper factories
- Textile industries

Accessori vedi a pag. 98 / Accessories see page 98





UGELLI ASSIALI A GETTO PIATTO - SERIE OV AXIAL-FEED VEE-JET NOZZLES – OV SERIES

OV

DATI OPERATIVI - OPERATIVE DATA

TIPO / TYPE OV y Dimensione raccordo Thread dimension		CODICE PORTATA FLOW CODE	PORTATA / FLOW l/min										AMPIEZZA ANGOLO DI SPRUZZO SPRAY ANGLE WIDTH				
3/8"	1/2"		0,5 bar	1 bar	1,5 bar	2 bar	3 bar	4 bar	5 bar	7 bar	10 bar	15 bar	25°	45°	60°	90°	120°
▼		144	2,7	3,8	4,7	5,4	6,6	7,6	8,5	10,1	12,1	15	●	●	●	●	●
▼		153	3,2	4,5	5,5	6,3	7,7	8,9	10,0	11,8	14	17	●	●	●	●	●
▼		170	4,0	5,7	6,9	8,0	9,8	11,3	12,6	15	18	22	●	●	●	●	●
▼		175	4,3	6,0	7,4	8,5	10,4	12,0	13	16	19	23	●	●	●	●	●
▼		185	4,8	6,7	8,2	9,5	11,6	13	15	18	21	26	●	●	●	●	●
▼		205	5,8	8,1	10,0	11,5	14	16	18	22	26	31	●	●	●	●	●
▼		215	6,3	8,8	10,8	12,5	15	18	20	23	28	34	●	●	●	●	●
▼		240	7,3	10,3	13	15	18	21	23	27	32	40	●	●	●	●	●
▼		260	8,5	12,0	15	17	21	24	27	32	38	47	●	●	●	●	●
▼		280	9,5	13	16	19	23	27	30	36	42	52	●	●	●	●	●
▼	▼	300	10,5	15	18	21	26	30	33	39	47	58	●	●	●	●	●
▼	▼	320	11,5	16	20	23	28	33	36	43	51	63	●	●	●	●	●
▼	▼	340	12,5	18	22	25	31	35	40	47	56	68	●	●	●	●	●
▼	▼	360	14	19	23	27	33	38	43	51	60	74	●	●	●	●	●
▼	▼	404	17	23	29	33	40	47	52	62	74	90	●	●	●	●	●
▼	▼	414	19	27	33	38	47	54	60	71	85	104	●	●	●	●	●
▼	▼	422	21	30	36	42	51	59	66	79	94	115	●	●	●	●	●
▼	▼	430	23	33	40	46	56	65	73	86	103	126	●	●	●	●	●
	▼	448	28	39	48	55	67	78	87	103	123	151	●	●	●	●	●
	▼	470	33	46	56	65	80	92	103	122	145	178	●	●	●	●	●
	▼	490	38	53	65	75	92	106	119	140	168	205	●	●	●	●	●
	▼	508	43	60	74	85	104	120	134	159	190	233	●	●	●	●	●
	▼	530	48	67	82	95	116	134	150	178	212	260	●	●	●	●	●
	▼	545	53	74	91	105	129	148	166	196	235	288	●	●	●	●	●
	▼	563	57	80	98	113	138	160	179	211	253	309	●	●	●	●	●

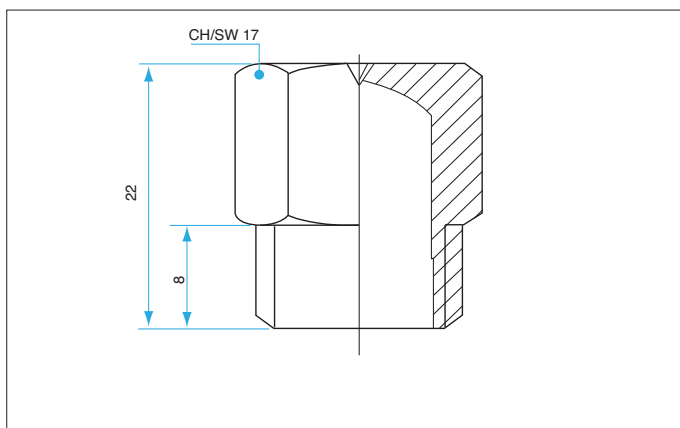

Tipo / Type OV y 3/8"

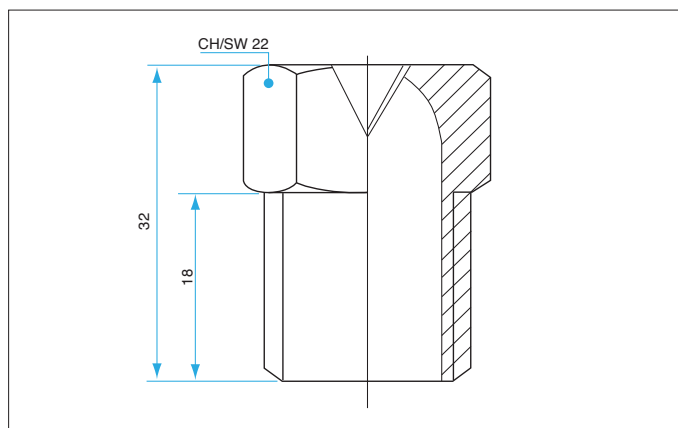

Tipo / Type OV y 1/2" NPT

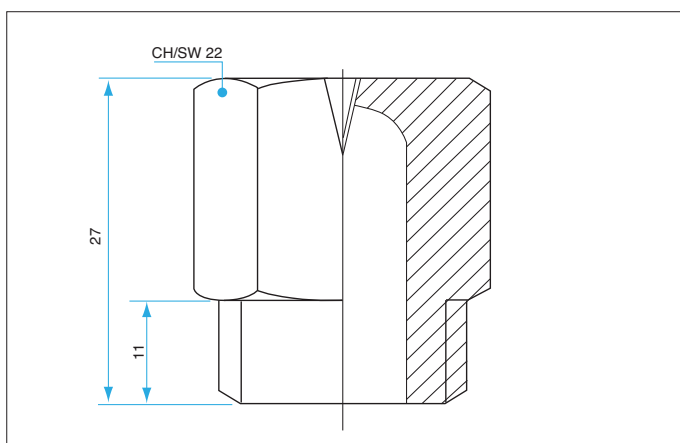

Tipo / Type OV y 1/2"

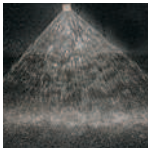

UGELLI ASSIALI A GETTO PIATTO - SERIE OV

AXIAL-FEED VEE-JET NOZZLES – OV SERIES

OV



Tipo / Type OV y 3/4"



Tipo / Type OV y 1"

CARATTERISTICHE

- Ricavati da barra esagonale e lavorati di precisione
- Ampia gamma di portate ed angoli di spruzzo
- Getto ben nebulizzato
- Gocce di media grandezza
- Elevata forza d'impatto
- La proiezione del getto ha estremità rastremate

CHARACTERISTICS

- Made out of hexagonal bar and precision machined
- Wide range of flows and spray angles
- Well nebulized jet
- Medium-sized droplets
- High impact force
- The jet projection has tapered ends

CODE STD.

MAT.

- 02 AISI 316
- 04 AISI 303
- 06 Ottone/Brass
- 07 Ottone nichelato cromato /Chromium-plated brass
- 08 PVC
- 09 Delrin
- 10 Polipropilene / Polypropylene

APPLICAZIONI CONSIGLIATE

- Lavaggio e raffreddamento materiali
- Trattamento delle superfici
- Lavaggio filtri
- Lavaggio nastri
- Raffreddamento serbatoi
- Controllo polveri
- Sistemi antincendio
- Lavatrici e lavastoviglie industriali
- Vasche galvaniche
- Industria siderurgica tessile e cartaria

TYPICAL APPLICATIONS

- Materials washing and cooling
- Surface treatment
- Filter washing
- Band washing
- Tanks cooling
- Dust control
- Fire fighting systems
- Industrial washing and dishwashing machines
- Galvanic bath tanks
- Iron and steel industries
- Paper factories
- Textile industries

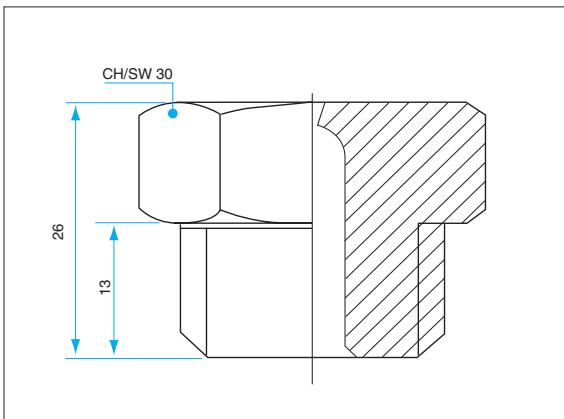

Tipo / Type OV y 3/4"

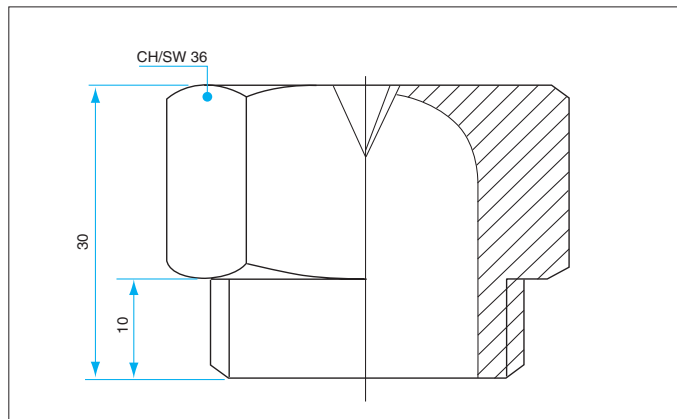

Tipo / Type OV y 1"

DATI OPERATIVI - OPERATIVE DATA

TIPO / TYPE OV y		CODICE PORTATA FLOW CODE	PORTATA / FLOW l/min										AMPIEZZA ANGOLO DI SPRUZZO SPRAY ANGLE WIDTH			
Dimensione raccordo Thread dimension			0,5 bar	1 bar	1,5 bar	2 bar	3 bar	4 bar	5 bar	7 bar	10 bar	15 bar	45°	60°	90°	120°
3/4"	1"	448	28	39	48	55	67	78	87	103	123	151	●	●	●	●
		470	33	46	56	65	80	92	103	122	145	178	●	●	●	●
		490	38	53	65	75	92	106	119	140	168	205	●	●	●	●
		508	43	60	74	85	104	120	134	159	190	233	●	●	●	●
		530	48	67	82	95	116	134	150	178	212	260	●	●	●	●
		545	53	74	91	105	129	148	166	196	235	288	●	●	●	●
		563	57	80	98	113	138	160	179	211	253	309	●	●	●	●
		602	63	89	109	126	154	178	199	236	282	345	●	●	●	●
		615	68	95	117	135	165	191	213	253	302	370	●	●	●	●
		627	74	104	127	147	180	208	232	275	329	403	●	●	●	●
		636	78	110	135	156	191	221	247	292	349	427	●	●	●	●
		648	84	119	145	168	206	238	266	314	376	460	●	●	●	●
		657	89	125	153	177	217	250	280	331	396	485	●	●	●	●
		667	93	131	160	185	227	262	293	346	414	507	●	●	●	●
		677	99	140	171	198	242	280	313	370	443	542	●	●	●	●
		690	105	148	182	210	257	297	332	393	470	575	●	●	●	●
		705	113	159	195	225	276	318	356	421	503	616	●	●	●	●

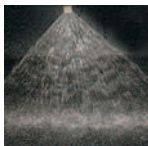

UGELLI ASSIALI A GETTO PIATTO - SERIE OV1

AXIAL-FEED VEE-JET NOZZLES – OV1 SERIES

OV



Tipo / Type OV1 y 1/4"



Tipo / Type OV1 y 3/8"

CARATTERISTICHE

- Ricavati da barra esagonale e lavorati di precisione
- Ampia gamma di portate ed angoli di spruzzo
- Getto ben nebulizzato
- Gocce di piccola e media grandezza
- Elevata forza d'impatto
- La proiezione del getto ha estremità rastremate
- Dimensioni ridotte

CHARACTERISTICS

- Made out of hexagonal bar and precision machined
- Wide range of flows and spray angles
- Well nebulized jet
- Small and medium-sized droplets
- High impact force
- The jet projection has tapered ends
- Small dimensions

CODE STD.

MAT.

- 02 AISI 316
- 04 AISI 303
- 06 Ottone/Brass
- 07 Ottone nichelato cromato /Chromium-plated brass
- 08 PVC
- 09 Delrin
- 10 Polipropilene / Polypropylene

APPLICAZIONI CONSIGLIATE

- Lavaggio e raffreddamento materiali
- Trattamento delle superfici
- Lavaggio filtri
- Lavaggio nastri
- Raffreddamento serbatoi
- Controllo polveri
- Sistemi antincendio
- Lavatrici e lavastoviglie industriali
- Vasche galvaniche
- Industria siderurgica tessile e cartaria

TYPICAL APPLICATIONS

- Materials washing and cooling
- Surface treatment
- Filter washing
- Band washing
- Tanks cooling
- Dust control
- Fire fighting systems
- Industrial washing and dishwashing machines
- Galvanic bath tanks
- Iron and steel industries
- Paper factories
- Textile industries

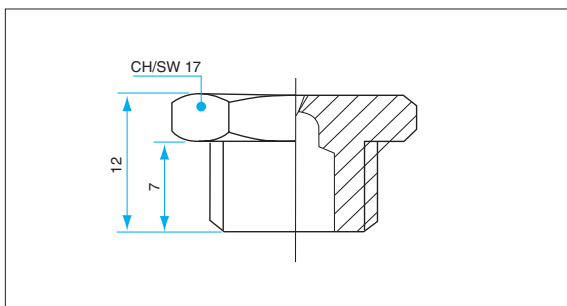

Tipo / Type OV1 y 1/4"

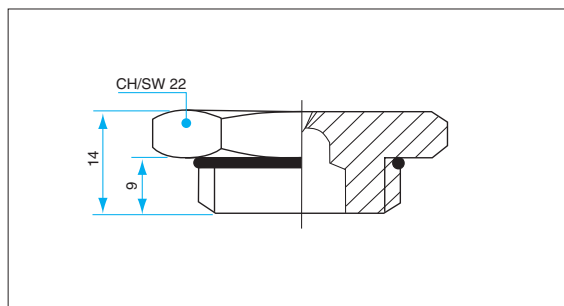

Tipo / Type OV1 y 3/8"

DATI OPERATIVI - OPERATIVE DATA

TIPO / TYPE OV1 y	Dimensione raccordo Thread dimension	CODICE PORTATA FLOW CODE	PORTATA / FLOW l/min									AMPIEZZA ANGOLO DI SPRUZZO SPRAY ANGLE WIDTH					
			0,5 bar	1 bar	1,5 bar	2 bar	3 bar	4 bar	5 bar	7 bar	10 bar	15 bar	25°	45°	60°	90°	120°
▼	1/4"	100	0,50	0,71	0,87	1,0	1,2	1,4	1,6	1,9	2,2	2,7	●	●	●	●	●
▼	1/4"	104	0,70	0,99	1,2	1,4	1,7	2,0	2,2	2,6	3,1	3,8	●	●	●	●	●
▼	1/4"	110	1,00	1,4	1,7	2,0	2,4	2,8	3,2	3,7	4,5	5,5	●	●	●	●	●
▼	1/4"	116	1,3	1,8	2,3	2,6	3,2	3,7	4,1	4,9	5,8	7,1	●	●	●	●	●
▼	1/4"	122	1,6	2,3	2,8	3,2	3,9	4,5	5,1	6,0	7,2	8,8	●	●	●	●	●
▼	1/4"	128	1,9	2,7	3,3	3,8	4,7	5,4	6,0	7,1	8,5	10,4	●	●	●	●	●
▼	1/4"	136	2,3	3,3	4,0	4,6	5,6	6,5	7,3	8,6	10,3	12,6	●	●	●	●	●
▼	3/8"	144	2,7	3,8	4,7	5,4	6,6	7,6	8,5	10,1	12,1	15	●	●	●	●	●
▼	3/8"	153	3,2	4,5	5,5	6,3	7,7	8,9	10,0	11,8	14	17	●	●	●	●	●
▼	3/8"	170	4,0	5,7	6,9	8,0	9,8	11,3	12,6	15	18	22	●	●	●	●	●
▼	3/8"	175	4,3	6,0	7,4	8,5	10,4	12,0	13	16	19	23	●	●	●	●	●
▼	3/8"	185	4,8	6,7	8,2	9,5	11,6	13	15	18	21	26	●	●	●	●	●
▼	3/8"	205	5,8	8,1	10,0	11,5	14	16	18	22	26	31	●	●	●	●	●
▼	3/8"	215	6,3	8,8	10,8	12,5	15	18	20	23	28	34	●	●	●	●	●
▼	3/8"	240	7,3	10,3	13	15	18	21	23	27	32	40	●	●	●	●	●
▼	3/8"	260	8,5	12,0	15	17	21	24	27	32	38	47	●	●	●	●	●
▼	3/8"	280	9,5	13	16	19	23	27	30	36	42	52	●	●	●	●	●
▼	3/8"	300	10,5	15	18	21	26	30	33	39	47	58	●	●	●	●	●
▼	3/8"	320	11,5	16	20	23	28	33	36	43	51	63	●	●	●	●	●
▼	3/8"	340	12,5	18	22	25	31	35	40	47	56	68	●	●	●	●	●
▼	3/8"	360	14	19	23	27	33	38	43	51	60	74	●	●	●	●	●
▼	3/8"	404	17	23	29	33	40	47	52	62	74	90	●	●	●	●	●

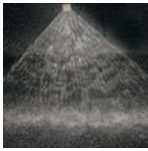

UGELLI ASSIALI A GETTO PIATTO - SERIE OV1

AXIAL-FEED VEE-JET NOZZLES – OV1 SERIES

OV



Tipo / Type OV1 y 1/2"



Tipo / Type OV1 y 3/4"

CARATTERISTICHE

- Ricavati da barra esagonale e lavorati di precisione
- Ampia gamma di portate ed angoli di spruzzo
- Getto ben nebulizzato
- Gocce di media grandezza
- Elevata forza d'impatto
- La proiezione del getto ha estremità rastremate
- Dimensioni ridotte

CHARACTERISTICS

- Made out of hexagonal bar and precision machined
- Wide range of flows and spray angles
- Well nebulized jet
- Medium-sized droplets
- High impact force
- The jet projection has tapered ends
- Small dimensions

CODE STD. MAT.

- 02 AISI 316
- 04 AISI 303
- 06 Ottone/Brass
- 07 Ottone nichelato cromato /Chromium-plated brass
- 08 PVC
- 09 Delrin
- 10 Polipropilene/Polypropylene

APPLICAZIONI CONSIGLIATE

- Lavaggio e raffreddamento materiali
- Trattamento delle superfici
- Lavaggio filtri
- Lavaggio nastri
- Raffreddamento serbatoi
- Controllo polveri
- Sistemi antincendio
- Lavatrici e lavastoviglie industriali
- Vasche galvaniche
- Industria siderurgica tessile e cartaria

TYPICAL APPLICATIONS

- Materials washing and cooling
- Surface treatment
- Filter washing
- Band washing
- Tanks cooling
- Dust control
- Fire fighting systems
- Industrial washing and dishwashing machines
- Galvanic bath tanks
- Iron and steel industries
- Paper factories
- Textile industries

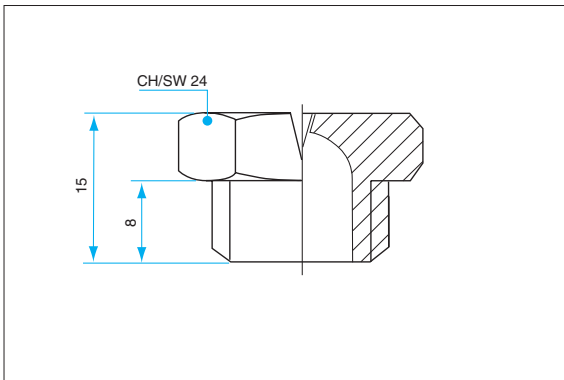

Tipo / Type OV1 y 1/2"

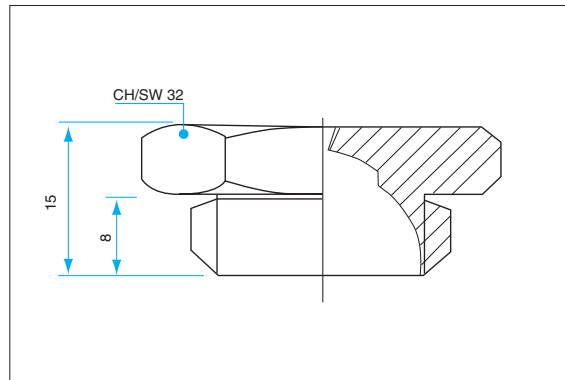

Tipo / Type OV1 y 3/4"

DATI OPERATIVI - OPERATIVE DATA

TIPO / TYPE OV1 y		CODICE PORTATA FLOW CODE	PORTATA / FLOW l/min										AMPIEZZA ANGOLO DI SPRUZZO SPRAY ANGLE WIDTH				
1/2"	3/4"		0,5 bar	1 bar	1,5 bar	2 bar	3 bar	4 bar	5 bar	7 bar	10 bar	15 bar	25°	45°	60°	90°	120°
▼		185	4,8	6,7	8,2	9,5	11,6	13	15	18	21	26	●	●	●	●	●
▼		205	5,8	8,1	10,0	11,5	14	16	18	22	26	31	●	●	●	●	●
▼		215	6,3	8,8	10,8	12,5	15	18	20	23	28	34	●	●	●	●	●
▼		240	7,3	10,3	13	15	18	21	23	27	32	40	●	●	●	●	●
▼		260	8,5	12,0	15	17	21	24	27	32	38	47	●	●	●	●	●
▼		280	9,5	13	16	19	23	27	30	36	42	52	●	●	●	●	●
▼		300	10,5	15	18	21	26	30	33	39	47	58	●	●	●	●	●
▼		320	11,5	16	20	23	28	33	36	43	51	63	●	●	●	●	●
▼		340	12,5	18	22	25	31	35	40	47	56	68	●	●	●	●	●
▼		360	14	19	23	27	33	38	43	51	60	74	●	●	●	●	●
▼	▼	404	17	23	29	33	40	47	52	62	74	90	●	●	●	●	●
▼	▼	415	19	27	33	38	47	54	60	71	85	104	●	●	●	●	●
▼	▼	422	21	30	36	42	51	59	66	79	94	115	●	●	●	●	●
▼	▼	430	23	33	40	46	56	65	73	86	103	126	●	●	●	●	●
▼	▼	448	28	39	48	55	67	78	87	103	123	151	●	●	●	●	●
▼	▼	470	33	46	56	65	80	92	103	122	145	178	●	●	●	●	●



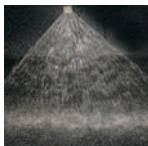

UGELLI ASSIALI A GETTO PIATTO - SERIE OVK/OVKIR AXIAL-FEED VEE-JET NOZZLES – OVK/OVKIR SERIES

OV

CODE STD.
MAT.
02 AISI 316
04 AISI 303

CARATTERISTICHE

- Dimensioni ridotte per sfruttare al massimo lo spazio disponibile
- Filettature metriche da **M4**

CHARACTERISTICS

- Small overall dimensions to exploit to the utmost the available space
- Metric thread from **M4**

APPLICAZIONI CONSIGLIATE

- Lavatrici e lavastoviglie industriali

TYPICAL APPLICATIONS

- Industrial washing and dishwashing machines



Tipo / Type OVK



Tipo / Type OVKIR

DATI OPERATIVI - OPERATIVE DATA

TIPO / TYPE OVK Dimensione raccordo / Thread dimension					CODICE PORTATA FLOW CODE	PORTATA / FLOW l/min										AMPIEZZA ANGOLO DI SPRUZZO SPRAY ANGLE WIDTH
IR	M4	M5	M6	M8		0,5 bar	1 bar	1,5 bar	2 bar	3 bar	4 bar	5 bar	7 bar	10 bar	15 bar	
▼	▼	▼	▼	▼	022	0,11	0,16	0,19	0,22	0,27	0,31	0,3	0,4	0,5	0,6	45° - 60° - 90° - 120°
▼	▼	▼	▼	▼	035	0,18	0,25	0,30	0,35	0,43	0,49	0,6	0,7	0,8	1,0	
▼	▼	▼	▼	▼	048	0,24	0,34	0,42	0,48	0,59	0,68	0,8	0,9	1,1	1,3	
▼	▼	▼	▼	▼	065	0,33	0,46	0,56	0,65	0,80	0,92	1,0	1,2	1,5	1,8	
▼	▼	▼	▼	▼	095	0,48	0,67	0,82	0,95	1,2	1,3	1,5	1,8	2,1	2,6	
▼	▼	▼	▼	▼	102	0,60	0,85	1,0	1,20	1,5	1,7	1,9	2,2	2,7	3,3	
▼	▼	▼	▼	▼	105	0,8	1,1	1,3	1,50	1,8	2,1	2,4	2,8	3,4	4,1	

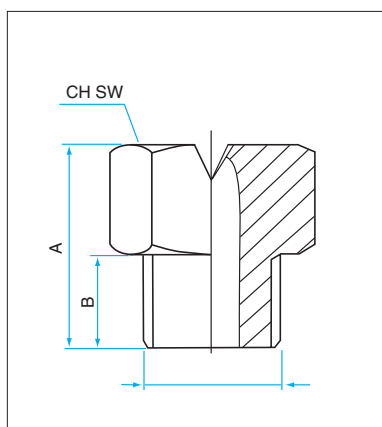

Tipo / Type OVK

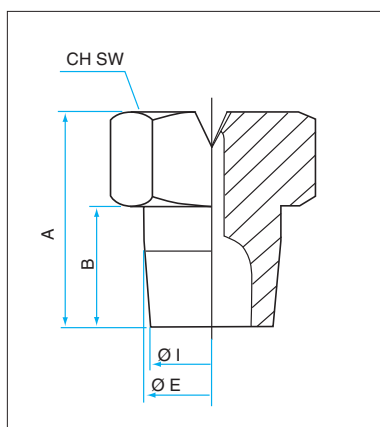

Tipo / Type OVKIR

DIMENSIONI - DIMENSIONS

	A	B	CH/SW	Ø I	Ø E
OVK	9	4	Es. 8	-	-
OVKIR	9,5	6	Es. 8	5,5	6,2

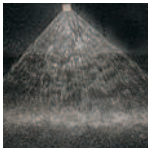

UGELLI ASSIALI A GETTO PIATTO - SERIE OVS GETTO ORIENTABILE

AXIAL-FEED VEE-JET NOZZLES – OVS SERIES REVOLVING JET

OV



Tipo / Type OVS y

CARATTERISTICHE

- Ricavato da barra
- Sfera ugello orientabile
- Inclinazione massima 30°
- Gocce di media grandezza
- Minori dimensioni di ingombro rispetto all'ugello standard installato sullo snodo (pag. 108)
- Materiali non standard a richiesta

APPLICAZIONI CONSIGLIATE

- Lavaggio e raffreddamento materiali
- Trattamento delle superfici
- Lavaggio filtri
- Lavaggio nastri
- Raffreddamento serbatoi
- Controllo polveri

CHARACTERISTICS

- Made out of bar
- Revolving ball-nozzles
- Adjusting of jet direction 30° max
- Medium-sized droplets
- Fewer overall dimensions than those ones of standard nozzle mounted on ball-joint (page 108)
- Not standard materials on request

TYPICAL APPLICATIONS

- Materials washing and cooling
- Surface treatment
- Filters washing
- Bands washing
- Tanks cooling
- Dust control

CODE STD.
MAT.
02 AISI 316
06 Ottone/Brass
08 PVC

DATI OPERATIVI - OPERATIVE DATA

TIPO / TYPE OVS y Dimensione raccordo / Thread dimension						CODICE PORTATA FLOW CODE	PORTATA / FLOW l/min										AMPIEZZA ANGOLO DI SPRUZZO SPRAY ANGLE WIDTH
1/8"	1/4"	3/8"	1/2"	3/4"	1"		Ø mm.	0,5 bar	1 bar	1,5 bar	2 bar	3 bar	4 bar	5 bar	7 bar	10 bar	
▼	▼	▼	▼			108	1,5	1,3	1,6	1,80	2,2	2,5	2,8	3,4	4,0	4,9	
▼	▼	▼	▼			110	1,6	1,4	1,7	2,00	2,4	2,8	3,2	3,7	4,5	5,5	
▼	▼	▼	▼			115	1,7	1,8	2,2	2,50	3,1	3,5	4,0	4,7	5,6	6,8	
▼	▼	▼	▼			118	1,8	2,0	2,4	2,8	3,4	4,0	4,4	5,2	6,3	7,7	
▼	▼	▼	▼			125	2,1	2,5	3,0	3,5	4,3	4,9	5,5	6,5	7,8	9,6	
▼	▼	▼	▼			136	2,4	3,3	4,0	4,6	5,6	6,5	7,3	8,6	10	13	
▼	▼	▼	▼			145	2,6	3,9	4,8	5,5	6,7	7,8	8,7	10	12	15	
▼	▼	▼	▼			155	2,8	4,6	5,6	6,5	8,0	9,2	10	12	15	18	
	▼	▼	▼			170	3,1	5,7	6,9	8,0	9,8	11	13	15	18	22	
	▼	▼	▼			183	3,5	6,6	8,1	9,3	11	13	15	17	21	25	
	▼	▼	▼			200	3,9	7,8	9,5	11,0	13	16	17	21	25	30	
	▼	▼	▼			215	4,3	8,8	11	12,5	15	18	20	23	28	34	
	▼	▼	▼			230	4,7	9,9	12	14,0	17	20	22	26	31	38	
	▼	▼	▼			260	5,0	12	15	17,0	21	24	27	32	38	47	
	▼	▼	▼			290	5,5	14	17	20,0	24	28	32	37	45	55	
		▼	▼			330	5,8	17	21	24,0	29	34	38	45	54	66	
		▼	▼	▼		380	6,2	21	25	29,0	36	41	46	54	65	79	
		▼	▼	▼		406	6,6	24	29	34,0	42	48	54	64	76	93	
		▼	▼	▼		416	7,0	28	34	39,0	48	55	62	73	87	107	
			▼	▼	▼	430	7,5	33	40	46,0	56	65	73	86	103	126	
			▼	▼	▼	460	8,1	42	52	60	73	85	95	112	134	164	
			▼	▼	▼	476	8,5	48	59	68	83	96	108	127	152	186	
				▼	▼	500	9,5	57	69	80	98	113	126	150	179	219	
					▼	562	11,5	78	95	110	135	156	174	206	246	301	

45° - 60° - 90°

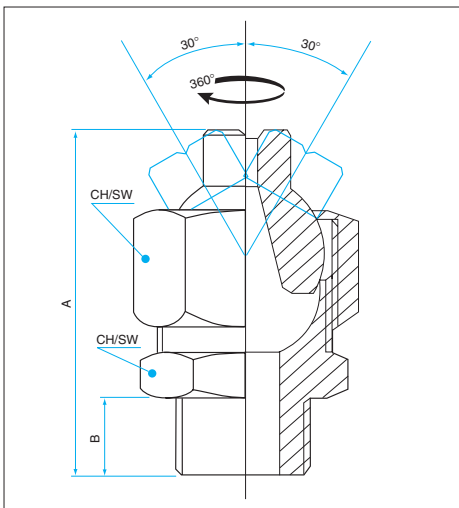

Tipo / Type OVS y

DIMENSIONI DIMENSIONS	RACCORDO MASCHIO GAS CILINDRICO BSP MALE BSP THREAD					
	1/8" y	1/4" y	3/8" y	1/2" y	3/4" y	1" y
A	42	42	42	42	55	55
B	10	10	10	10	13	13
CH/SW	22/24	22/24	22/24	22/24	36	36

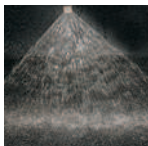

SFERA-UGELLI A GETTO PIATTO - SERIE OVSW

VEE-JET BALL-NOZZLES – OVSW SERIES

OV



Tipo / Type OVSW
1/2" - 3/4" - 1"



Tipo / Type OVSW
1"-1 1/4 - 1 1/2 - 2"

CARATTERISTICHE

- Sfera-ugelli dotati di attacco rapido con fascetta a molla
- Possibilità di orientare con precisione la direzione del getto in base alle esigenze di installazione
- Pressione di esercizio consigliata max 5 bar
- Resistenza alla corrosione e a temperature elevate (max 70° C)

APPLICAZIONI CONSIGLIATE

- Impianti di lavaggio e fosfatazione

MATERIALI

- Molla in acciaio inox AISI 316 normalizzato
- Porta-sfera, sfera-ugello e ghiera stampati in polipropilene + F.V.
- O-ring in NBR, a richiesta in VITON

CHARACTERISTICS

- Ball-nozzles equipped with quick clamp connector
- Precise adjusting of the jet direction according to your plant's needs
- Very good seal at pressure up to 5 bar
- Good corrosion and high temperature resistance (max 70° C)

TYPICAL APPLICATIONS

- Degreasing and phosphating plants

MATERIALS

- Clamp: AISI 316 normalized stainless steel
- Ball-holder, ball-nozzle and screwed nut polypropylene glass/filled molded
- NBR O-ring, or VITON on request

DATI OPERATIVI - OPERATIVE DATA

TIPO / TYPE OVSW Dimensione tubo / Pipe dimension						CODICE PORTATA FLOW CODE	PORTATA / FLOW l/min						AMPIEZZA ANGOLO DI SPRUZZO SPRAY ANGLE WIDTH
1/2"	3/4"	1"	1 1/4"	1 1/2"	2"		0,5 bar	1 bar	1,5 bar	2 bar	3 bar	5 bar	
▼	▼					115	1,25	1,77	2,17	2,5	3,06	3,95	45° - 60° - 90° - 120°
▼	▼	▼				125	1,75	2,47	3,03	3,5	4,29	5,5	
▼	▼	▼				136	2,30	3,25	3,98	4,6	5,6	7,3	
▼	▼	▼				145	2,75	3,89	4,76	5,5	6,7	8,7	
▼	▼	▼	▼			155	3,25	4,60	5,6	6,5	8,0	10,3	
	▼	▼	▼	▼	▼	170	4,00	5,7	6,9	8,0	9,8	12,6	
	▼	▼	▼	▼	▼	183	4,65	6,6	8,1	9,3	11,4	14,7	
	▼	▼	▼	▼	▼	200	5,5	7,8	9,5	11,0	13,5	17,4	
	▼	▼	▼	▼	▼	215	6,3	8,8	10,8	12,5	15,3	19,8	
	▼	▼	▼	▼	▼	230	7,0	9,9	12,1	14,0	17,1	2	
	▼	▼	▼	▼	▼	260	8,5	12,0	14,7	17,0	21	27	
	▼	▼	▼	▼	▼	290	10,0	14,1	17,3	20,0	24	32	

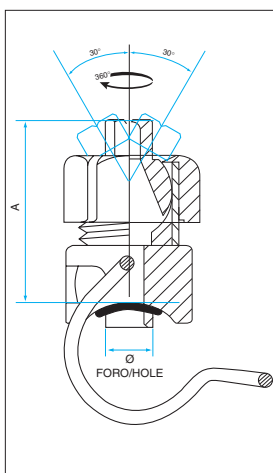

Tipo / Type OVSW
1/2" - 3/4" - 1"

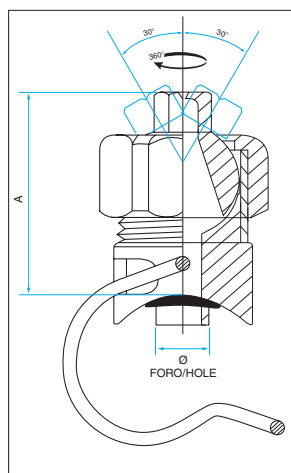

Tipo / Type OVSW
1"-1 1/4 - 1 1/2 - 2"

DIMENSIONI DIMENSIONS	OVSW					
	1/2"	3/4"	1"	1 1/4"	1 1/2"	2"
A	46	46	46/56	56	56	56
Ø foro sul tubo/hole on pipe	9	11	13	15 - 21	15	15
Colore/Colour						

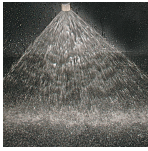

SFERA-UGELLI A GETTO PIATTO - SERIE OVSW-IR / OVSW-IRI VEE-JET BALL-NOZZLES – OVSW-IR / OVSW-IRI SERIES

OV

RIPOSIZIONAMENTO A MEMORIA / MEMO REPLACING



Tipo / Type OVSW-IR



Tipo / Type OVSW-IRI

CARATTERISTICHE

- Montaggio rapido con fascetta a molla in acciaio INOX AISI 316 normalizzato
- Pressione di esercizio consigliata max 5 bar
- Resistenza alla corrosione e a temperature elevate (max 70° C)
- Tipo OVSW-IRI punta di spruzzo con inserto in acciaio inox AISI 303/AISI 316 oppure in ottone

APPLICAZIONI CONSIGLIATE

- Impianti di sgrassaggio e fosfatazione

MATERIALI

- Molla in acciaio inox AISI 316 normalizzato
- Porta-sfera, sfera-ugello e ghiera stampati in polipropilene + F.V.
- O-ring in NBR, a richiesta in VITON

CHARACTERISTICS

- Fast mounting with normalized AISI 316 stainless steel spring clamp connector
- Very good seal at pressure up to 5 bar
- Good corrosion and high temperature resistance (max 70° C)
- Type OVSW-IRI spray head having AISI 303/AISI 316 stainless steel or brass insert

TYPICAL APPLICATIONS

- Degreasing and phosphating plants

MATERIALS

- Clamp: AISI 316 normalized stainless steel
- Ball-holder, ball-nozzle and screwed nut polypropylene glass/filled molded
- NBR O-ring, or VITON on request

DATI OPERATIVI - OPERATIVE DATA

TIPO / TYPE OVSW-IR Dimensione tubo / Pipe dimension				CODICE PORTATA FLOW CODE	PORTATA / FLOW l/min*						AMPIEZZA ANGOLO DI SPRUZZO SPRAY ANGLE WIDTH
1"	1"1/4	1"1/2	2"		0,5 bar	1 bar	1,5 bar	2 bar	3 bar	5 bar	
▼	▼	▼	▼	155	3,25	4,60	5,6	6,5	8,0	10,3	45° - 60° - 90° - 120°
▼	▼	▼	▼	170	4,00	5,7	6,9	8,0	9,8	12,6	
▼	▼	▼	▼	183	4,65	6,6	8,1	9,3	11,4	14,7	
▼	▼	▼	▼	200	5,5	7,8	9,5	11,0	13,5	17,4	
▼	▼	▼	▼	215	6,3	8,8	10,8	12,5	15,3	19,8	
▼	▼	▼	▼	230	7,0	9,9	12,1	14,0	17,1	22	
▼	▼	▼	▼	260	8,5	12,0	14,7	17,0	21	27	
▼	▼	▼	▼	290	10,0	14,1	17,3	20,0	24	32	

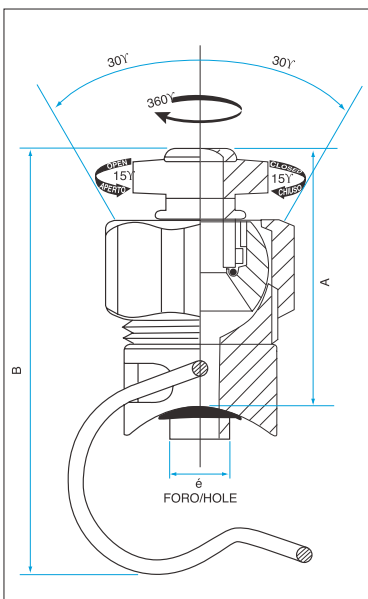

Tipo / Type OVSW-IR

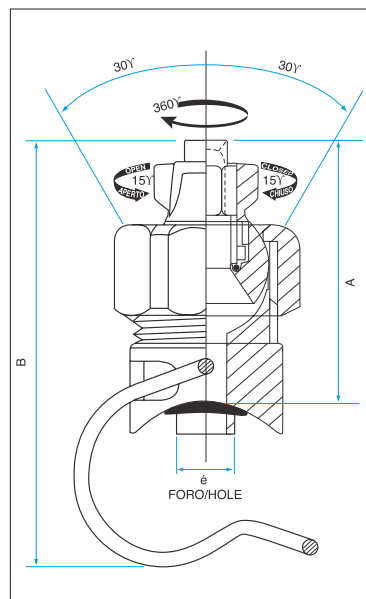

Tipo / Type OVSW-IRI

DIMENSIONI DIMENSIONS	OVSW-IR OVSW-IRI			
	1"	1" 1/4	1" 1/2	2"
B	100	100	100	100
A	60	60	60	60
Ø foro sul tubo/hole on pipe	13	15 - 21	15	15
Colore/Colour				



PUNTE DI SPRUZZO A GETTO PIATTO - SERIE OVW-IR / OVW-IRI VEE-JET SPRAY-CAPS – OVW-IR / OVW-IRI SERIES

OV

RIPOSIZIONAMENTO A MEMORIA / MEMO REPLACING



Tipo / Type OVW-IR



Tipo / Type OVW-IRI

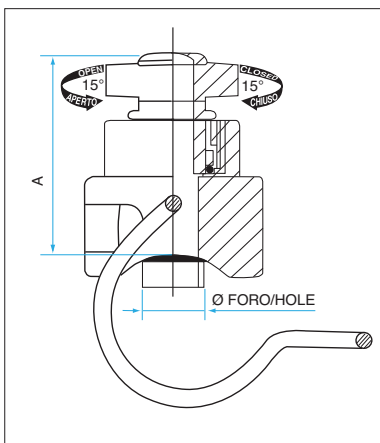

Tipo / Type OVW-IR

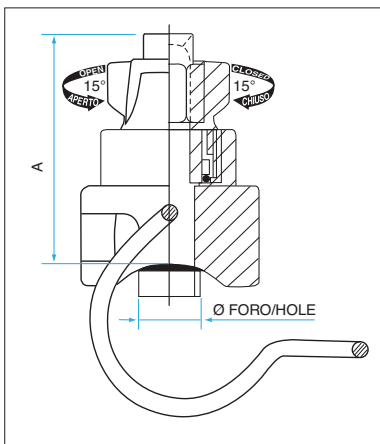

Tipo / Type OVW-IRI

CARATTERISTICHE

- Punte di spruzzo dotate di attacco rapido con fascetta a molla
- Pressione di esercizio consigliata max 5 bar
- Resistenza alla corrosione e a temperature elevate (max 70° C)
- Tipo OVW-IRI punta di spruzzo con inserto in acciaio inox AISI 303/AISI 316, oppure in ottone

APPLICAZIONI CONSIGLIATE

- Impianti di lavaggio e fosfatazione

MATERIALI

- Molla in acciaio inox AISI 316 normalizzato
- Porta-ugello e ugello stampati in polipropilene + F.V.
- O-ring in NBR, a richiesta in VITON

CHARACTERISTICS

- Spray-caps equipped with quick clamp connector
- Very good seal at pressure up to 5 bar
- Good corrosion and high temperature resistance (max 70° C)
- Type OVW-IRI spray-head having AISI 303/AISI 316 stainless steel or brass insert

TYPICAL APPLICATIONS

- Degreasing and phosphating plants

MATERIALS

- Clamp: AISI 316 normalized stainless steel
- Nozzle-holder: polypropylene glass/filled molded
- NBR O-ring, or VITON on request

DATI OPERATIVI - OPERATIVE DATA

TIPO / TYPE OVW-IR / OVW-IRI Dimensione tubo / Pipe dimension				CODICE PORTATA FLOW CODE	PORTATA / FLOW l/min						AMPIEZZA ANGOLO DI SPRUZZO SPRAY ANGLE WIDTH
1/2"	3/4"	1"	1"1/4"		0,5 bar	1 bar	1,5 bar	2 bar	3 bar	5 bar	
▼	▼			115	1,25	1,77	2,17	2,5	3,06	3,95	45° - 60° - 90° - 120°
▼	▼	▼		125	1,75	2,47	3,03	3,5	4,29	5,5	
▼	▼	▼		136	2,30	3,25	3,98	4,6	5,6	7,3	
▼	▼	▼		145	2,75	3,89	4,76	5,5	6,7	8,7	
▼	▼	▼	▼	155	3,25	4,60	5,6	6,5	8,0	10,3	
		▼	▼	170	4,00	5,7	6,9	8,0	9,8	12,6	
		▼	▼	183	4,65	6,6	8,1	9,3	11,4	14,7	
		▼	▼	200	5,5	7,8	9,5	11,0	13,5	17,4	
		▼	▼	215	6,3	8,8	10,8	12,5	15,3	19,8	
		▼	▼	230	7,0	9,9	12,1	14,0	17,1	2	
		▼	▼	260	8,5	12,0	14,7	17,0	21	27	
		▼	▼	290	10,0	14,1	17,3	20,0	24	32	

DIMENSIONI DIMENSIONS	OVW-IR				OVW-IRI			
	1/2"	3/4"	1"	1" 1/4	1/2"	3/4"	1"	1" 1/4
A	44	44	44	46	44	44	44	46
Ø foro sul tubo/hole on pipe	9	11	13	15	9	11	13	15
Colore/Colour	Yellow	Green	Blue	Orange	Yellow	Green	Blue	Orange



UGELLI A GETTO PIATTO PER ARIA E VAPORE SERIE A/V FLAT-JET NOZZLES FOR AIR AND STEAM – A/V SERIES

AV



Tipo / Type A/V y



Tipo / Type A/V S

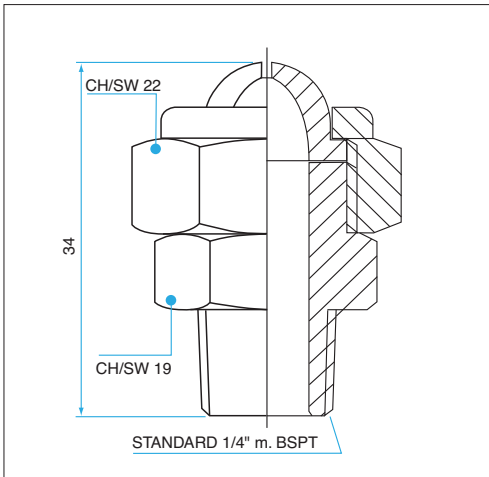

Tipo / Type A/V y

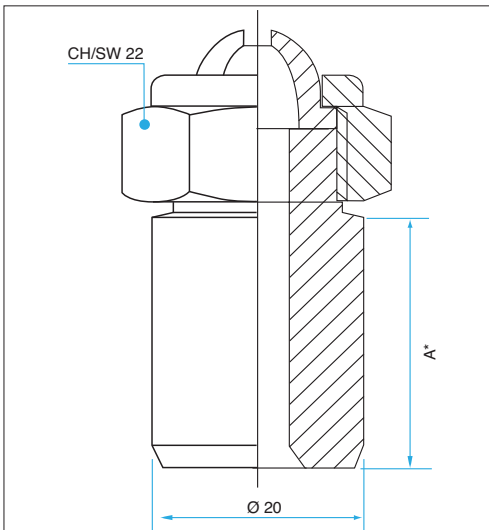

Tipo / Type A/V S

*A: Lunghezza variabile a richiesta
Variable lenght on request

CARATTERISTICHE

- Ricavati da barra esagonale e lavorati di precisione
- Il getto è piatto ed ha distribuzione uniforme
- Particolarmente indicati per la spruzzatura di aria e vapore
- Costruiti in tre pezzi con testine di spruzzo rimovibili ed intercambiabili, per facilitare la pulizia ed il controllo

APPLICAZIONI CONSIGLIATE

- Impianti tessili
- Soffiaggio ed asciugatura industriale
- Cappe di aspirazione

CHARACTERISTICS

- Made out of hexagonal bar and precision machined
- The jet is flat with an uniform distribution
- Especially suitable for air and steam spraying
- The types consist of three pieces with removable and interchangeable spray heads to make the cleaning and control operations easier

TYPICAL APPLICATIONS

- Textile plants
- Industrial blow and drying
- Hoods

CODE STD.

MAT.
02 AISI 316
04 AISI 303
06 Ottone/Brass

DATI OPERATIVI - OPERATIVE DATA

Codice portata Flow code	PORTATA ARIA - AIR FLOW l/min									AMPIEZZA ANGOLO DI SPRUZZO SPRAY ANGLE WIDTH
	Ø mm	0,8 bar	1,5 bar	2 bar	3 bar	4 bar	5 bar	6 bar	6 bar	
A01	0,70	6,1	8,4	9,7	11,8	13,6	15,3	16,7	19,3	90°
A02	0,85	7,9	10,9	12,5	15,4	17,7	19,8	21,7	25,1	
A03	1,00	11,8	16,2	18,7	22,9	26,5	30	32	37	
A04	1,20	15,9	21,7	25,1	31	35	40	43	50	
A05	1,40	19,5	26,7	31	38	44	49	53	62	
A06	1,50	24,4	33	39	47	55	61	67	77	
A07	1,70	33	45	52	64	74	82	90	104	
A08	1,90	40	55	64	78	90	101	110	127	
A09	2,20	59	80	93	113	131	146	160	185	
A10	2,50	68	94	108	132	153	171	187	216	
A11	2,70	79	109	125	154	177	198	217	251	
A12	2,90	93	127	147	180	207	232	254	293	
A13	3,20	116	159	183	225	259	290	318	367	
A14	3,50	140	192	222	272	314	351	384	444	
A15	3,80	153	209	241	295	341	381	418	483	
A16	4,00	171	234	270	331	382	427	468	540	
A17	4,30	208	284	328	402	464	519	568	656	
A18	4,60	232	318	367	449	519	580	635	733	
A19	5,00	269	368	425	520	600	671	735	849	

Codice portata Flow code	PORTATA VAPORE - STEAM FLOW KG/H									AMPIEZZA ANGOLO DI SPRUZZO SPRAY ANGLE WIDTH
	Ø mm	0,8 bar	1,5 bar	2 bar	3 bar	4 bar	5 bar	6 bar	6 bar	
V01	0,70	0,45	0,62	0,72	0,88	1,01	1,1	1,2	1,4	90°
V02	0,85	0,59	0,80	0,93	1,14	1,3	1,5	1,6	1,9	
V03	1,00	0,88	1,2	1,4	1,7	2,0	2,2	2,4	2,8	
V04	1,20	1,2	1,6	1,9	2,3	2,6	2,9	3,2	3,7	
V05	1,40	1,4	2,0	2,3	2,8	3,2	3,6	4,0	4,6	
V06	1,50	1,8	2,5	2,9	3,5	4,0	4,5	5,0	5,7	
V07	1,70	2,4	3,3	3,9	4,7	5,5	6,1	6,7	7,7	
V08	1,90	3,0	4,1	4,7	5,8	6,7	7,5	8,2	9,4	
V09	2,20	4,3	5,9	6,9	8,4	9,7	10,9	11,9	13,7	
V10	2,50	5,1	6,9	8,0	9,8	11,3	12,7	13,9	16,0	
V11	2,70	5,9	8,0	9,3	11,4	13,1	14,7	16,1	18,6	
V12	2,90	6,9	9,4	10,9	13,3	15,4	17,2	18,8	21,7	
V13	3,20	8,6	11,8	13,6	16,6	19,2	21,5	23,5	27,2	
V14	3,50	10,4	14,2	16,4	20,1	23,3	26,0	28,5	33,0	
V15	3,80	11,3	15,5	17,9	21,9	25,3	28,3	31,0	36,0	
V16	4,00	12,7	17,3	20,0	24,5	28,3	32,0	35,0	40,0	
V17	4,30	15,4	21,1	24,3	30,0	34,0	38,0	42,0	49,0	
V18	4,60	17,2	23,5	27,2	33,0	38,0	43,0	47,0	54,0	
V19	5,00	19,9	27,2	31,0	39,0	44,0	50,0	54,0	63,0	



UGELLI ASSIALI A GETTO PIATTO - SERIE PV

AXIAL FEED VEE-JET NOZZLES – PV SERIES

PV

CODE STD.
MAT.
02 AISI 316
06 Ottone/Brass



Tipo / Type PV 1/4" y



Tipo / Type
PV 10P1 x - 11P1 x - 11P1,25 x

CARATTERISTICHE

- Appositamente progettati per la spruzzatura di olii chimici
- Ricavati da barra
- Costruiti in tre pezzi facilmente smontabili per pulizia e controllo
- Pastiglie di spruzzo rimovibili ed intercambiabili
- Angolo di spruzzo a 60°
- Buona nebulizzazione dell'olio chimico a pressioni non superiori a 6 bar

CHARACTERISTICS

- Especially designed for chemical oils spraying
- Made out of bar
- Consist of three pieces and can be easily disassembled for cleaning and control
- Removable and interchangeable spraying inserts
- Spray angle at 60°
- Good nebulization of the sprayed chemical oil at pressure not higher than 6 bar

APPLICAZIONI CONSIGLIATE

- Spruzzatura di olii in genere
- Spruzzatura di olii disarmanti per prefabbricati
- Trattamenti chimici in genere

TYPICAL APPLICATIONS

- Oil spraying in general
- Spraying of withdrawing oil for prefabs
- Chemical treatments in general

DATI OPERATIVI - OPERATIVE DATA

TIPO / TYPE PV Dimensione raccordo / Thread dimension			CODICE PORTATA FLOW CODE	PORTATA / FLOW l/min					AMPIEZZA ANGOLO DI SPRUZZO SPRAY ANGLE WIDTH	
10P1 - 11P1 x	11P1,25 x	1/4" y		Ø mm	2 bar	3 bar	4 bar	5 bar		6 bar
▼	▼	▼	021	0,2	0,06	0,07	0,08	0,09	0,10	60°
▼	▼	▼	031	0,3	0,08	0,10	0,12	0,13	0,14	
▼	▼	▼	041	0,4	0,12	0,15	0,17	0,19	0,21	
▼	▼	▼	051	0,5	0,20	0,25	0,29	0,32	0,35	
▼	▼	▼	061	0,6	0,29	0,36	0,42	0,46	0,51	
▼	▼	▼	071	0,7	0,41	0,50	0,58	0,65	0,71	
▼	▼	▼	081	0,8	0,49	0,60	0,69	0,77	0,85	
▼	▼	▼	091	0,9	0,63	0,77	0,89	0,99	1,1	
▼	▼	▼	101	1,0	0,90	1,1	1,3	1,4	1,6	
▼	▼	▼	121	1,2	1,2	1,5	1,7	1,9	2,1	
▼	▼	▼	151	1,5	1,7	2,1	2,4	2,7	3,0	
▼	▼	▼	181	1,8	2,4	3,0	3,5	3,9	4,2	
▼	▼	▼	211	2,1	3,3	4,0	4,6	5,2	5,7	
▼	▼	▼	251	2,5	4,7	5,8	6,7	7,5	8,2	

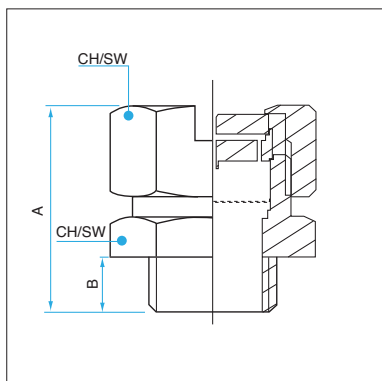

Tipo / Type PV 1/4" y

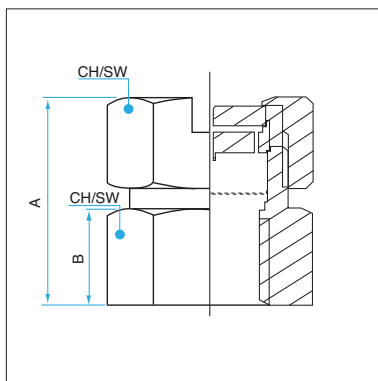

Tipo / Type
PV 10P1 x - 11P1 x - 11P1,25 x

DIMENSIONI DIMENSIONS	PV			
	10P1 x	11P1 x	11P1,25 x	1/4" y
A	21	21	21	21
B	8	8	8	8
CH/SW	19	19	19	19

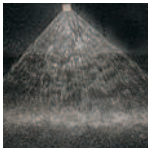

UGELLI ASSIALI A GETTO PIATTO - SERIE PVT

AXIAL FEED VEE-JET NOZZLES - PVT SERIES

PV



Tipo / Type PVT x



Tipo / Type PVT S

CARATTERISTICHE

- Costruito in tre pezzi: testa di spruzzo, nipplo e ghiera filettata
- Teste intercambiabili e rimovibili per facilitare le operazioni di pulizia e controllo
- La direzione del getto può essere fissa, grazie all'innesto a coda di rondine, oppure orientabile
- A richiesta sono dotati di filtro e valvolina di non-ritorno
- Getto ben nebulizzato
- Media forza d'impatto

CHARACTERISTICS

- Consists in three pieces: spray head, nipple and ring nut
- Interchangeable and removable heads to make cleaning and control operations easier
- The jet direction can be fixed by means of dove-tail connection, or revolving
- On request they are equipped with strainer and non return valve
- Well atomized jet
- Medium impact force

CODE STD.

MAT.
02 AISI 316
04 AISI 303
06 Ottone/Brass
08 PVC
09 Delrin
10 Polipropilene/
Polypropylene
36 Teflon
21 PVDF

APPLICAZIONI CONSIGLIATE

- Lavaggio e raffreddamento materiali
- Trattamento delle superfici
- Lavaggio filtri
- Lavaggio nastri
- Raffreddamento cilindri di laminatoi
- Industria siderurgica tessile e cartaria

TYPICAL APPLICATIONS

- Material washing and cooling
- Surface treatment
- Filters washing
- Bands washing
- Rolls cooling
- Iron and steel industries
- Paper factories
- Textile industries

DATI OPERATIVI - OPERATIVE DATA

	CODICE PORTATA FLOW CODE	PORTATA / FLOW l/min										AMPIEZZA ANGOLO DI SPRUZZO SPRAY ANGLE WIDTH
		0,5 bar	1 bar	1,5 bar	2 bar	3 bar	4 bar	5 bar	7 bar	10 bar	15 bar	
TIPO / TYPE T1 - T1K* - T1R* Punta di spruzzo Spray head	085		0,46	0,56	0,65	0,80	0,92	1,0	1,2	1,5	1,8	30° - 45° - 60° 90° - 120°
	095		0,67	0,82	0,95	1,2	1,3	1,5	1,8	2,1	2,6	
	102		0,85	1,0	1,20	1,5	1,7	1,9	2,2	2,7	3,3	
	105		1,1	1,3	1,50	1,8	2,1	2,4	2,8	3,4	4,1	
	108		1,3	1,6	1,80	2,2	2,5	2,8	3,4	4,0	4,9	
	110	1,0	1,4	1,7	2,00	2,4	2,8	3,2	3,7	4,5	5,5	
	115	1,3	1,8	2,2	2,50	3,1	3,5	4,0	4,7	5,6	6,8	
	118	1,4	2,0	2,4	2,8	3,4	4,0	4,4	5,2	6,3	7,7	
	125	1,8	2,5	3,0	3,5	4,3	4,9	5,5	6,5	7,8	9,6	
	136	2,3	3,3	4,0	4,6	5,6	6,5	7,3	8,6	10	13	
	145	2,8	3,9	4,8	5,5	6,7	7,8	8,7	10	12	15	
	155	3,3	4,6	5,6	6,5	8,0	9,2	10	12	15	18	
	170	4,0	5,7	6,9	8,0	9,8	11	13	15	18	22	
	183	4,7	6,6	8,1	9,3	11	13	15	17	21	25	
	200	5,5	7,8	9,5	11,0	13	16	17	21	25	30	
215	6,3	8,8	11	12,5	15	18	20	23	28	34		
230	7,0	9,9	12	14,0	17	20	22	26	31	38		

* A richiesta possibilità di disassamento getto da 0° a 90° / Jet offset from 0° to 90° on request

DATI OPERATIVI - OPERATIVE DATA

	CODICE PORTATA FLOW CODE	PORTATA / FLOW l/min										AMPIEZZA ANGOLO DI SPRUZZO SPRAY ANGLE WIDTH
		0,5 bar	1 bar	1,5 bar	2 bar	3 bar	4 bar	5 bar	7 bar	10 bar	15 bar	
TIPO / TYPE T2 - T2K* - T2R* Punta di spruzzo Spray head	260	8,5	12	15	17,0	21	24	27	32	38	47	30° - 45° - 60° 90° - 120°
	290	10	14	17	20,0	24	28	32	37	45	55	
	330	12	17	21	24,0	29	34	38	45	54	66	
	380	15	21	25	29,0	36	41	46	54	65	79	
	406	17	24	29	34,0	42	48	54	64	76	93	
	416	20	28	34	39,0	48	55	62	73	87	107	
	430	23	33	40	46,0	56	65	73	86	103	126	
	460	30	42	52	60	73	85	95	112	134	164	
	476	34	48	59	68	83	96	108	127	152	186	
	500	40	57	69	80	98	113	126	150	179	219	
	562	55	78	95	110	135	156	174	206	246	301	

* A richiesta possibilità di disassamento getto da 0° a 90° / Jet offset from 0° to 90° on request



UGELLI ASSIALI A GETTO PIATTO - SERIE PVT GETTO ORIENTABILE AXIAL FEED VEE-JET NOZZLES – PVT SERIES REVOLVING JET

PV

SERIE / SERIES "T"

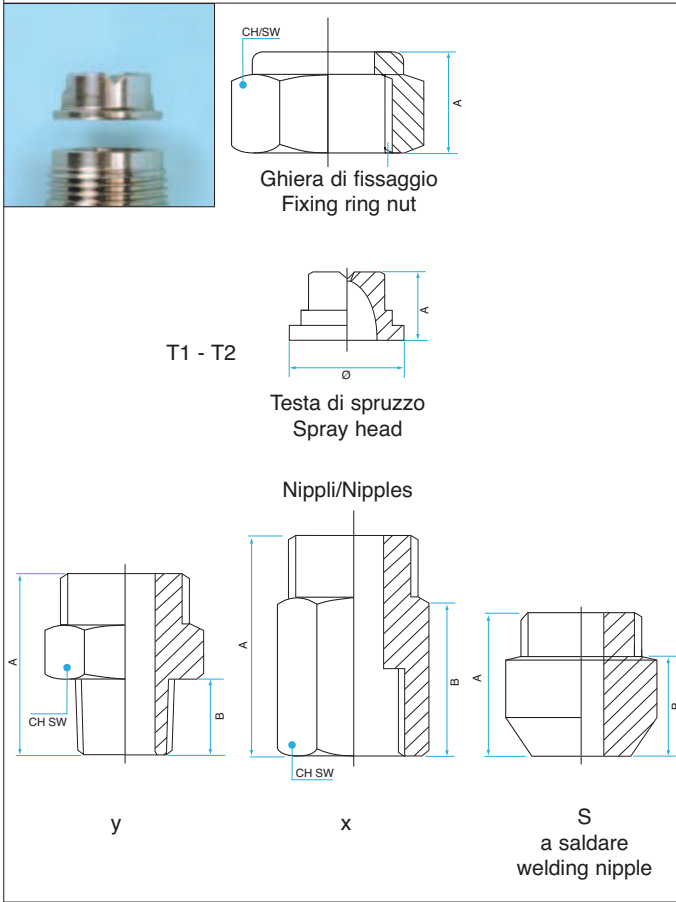

SERIE / SERIES "TK"

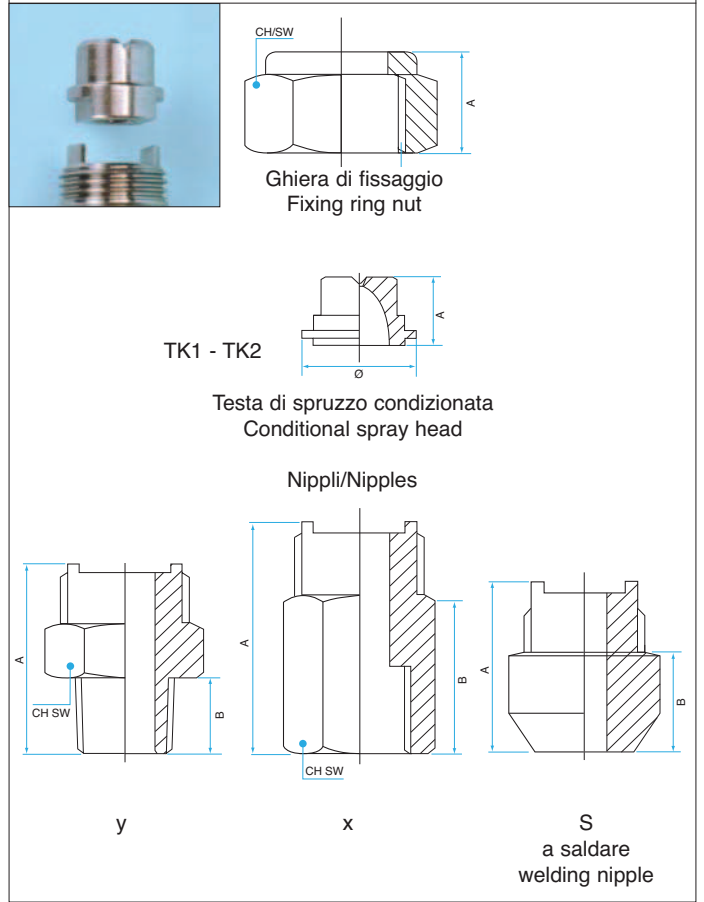

SERIE / SERIES "TR"

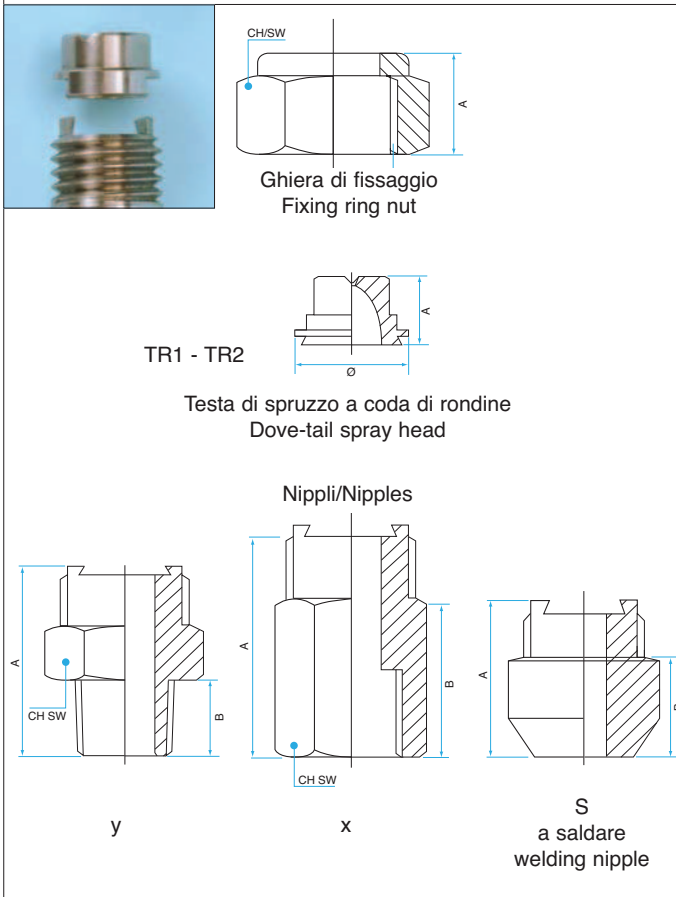

DIMENSIONI DIMENSIONS	GHIERA DI FISSAGGIO FIXING RING NUT	
	PER SERIE T1/FOR T1 SERIES	PER SERIE T2/FOR T2 SERIES
A	12	15
Filetto/Thd	3/8"	3/4"
CH/SW	22	30

DIMENSIONI DIMENSIONS	TESTE DI SPRUZZO / SPRAY HEADS					
	T1	TK1	TR1	T2	TK2	TR2
Ø	15	15	15	24	24	24
A	12	12	12	14	14	14
B	-	-	-	-	-	-

DIMENSIONI DIMENSIONS	NIPPLI PER / NIPPLES FOR					
	T1 / TK1 / TR1			T2 / TK2 / TR2		
	S	X	Y	S	X	Y
		1/4"	1/4"-3/8"		1/2"-3/4"	1/2"-3/4"
A	22	27	30	26	33	35
B	20	-	-	30	-	-
CH/SW	-	17	17	-	27	27

UGELLI ASSIALI A GETTO PIATTO - SERIE OL

AXIAL FEED FLAT-JET NOZZLES – OL SERIES

OL



Tipo / Type OL δ 75°



Tipo / Type OL δ 45°



Tipo / Type OL δ 90°



Tipo / Type OL δ 30°

CARATTERISTICHE

- Ricavati da barra esagonale e lavorati di precisione soprattutto sulla superficie di deflessione
- La presenza di un solo foro di passaggio riduce la possibilità di intasamento degli ugelli
- Getto piatto ed ampio con estremità ben delineate
- Gocce di media grandezza
- Media forza d'impatto
- Ampia gamma di portate

APPLICAZIONI CONSIGLIATE

- Raffreddamento materiali
- Lavaggio pellicole
- Lavaggio filtri
- Sistemi antincendio
- Impianti di verniciatura

CHARACTERISTICS

- Made out of hexagonal bar and precision machined, above all on the deflection surface
- Low-clogging characteristics owing to the presence of one passage hole only
- The jet is flat and wide with well delineated ends
- Medium-sized droplets
- Medium impact force
- Wide range of flows

TYPICAL APPLICATIONS

- Materials cooling
- Films washing
- Filters washing
- Fire-fighting systems
- Spray paint plants

CODE STD. MAT.
02 AISI 316
04 AISI 303
06 Ottone/Brass
08 PVC



UGELLI ASSIALI A GETTO PIATTO - SERIE OL

AXIAL FEED FLAT-JET NOZZLES – OL SERIES

OL

DATI OPERATIVI - OPERATIVE DATA

TIPO/TYPE OL y Dimensione raccordo - Thread dimension						CODICE PORTATA FLOW CODE	PORTATA / FLOW l/min										AMPIEZZA ANGOLO DI SPRUZZO SPRAY ANGLE WIDTH		
1/8"	1/4"	3/8"	1/2"	3/4"	1"		Ø mm.	0,5 bar	1 bar	1,5 bar	2 bar	3 bar	5 bar	7 bar	10 bar	90°	120°	150°	
▼	▼					030	0,6	0,15	0,21	0,26	0,30	0,37	0,47	0,6	0,7	●	●	●	
▼	▼					065	0,8	0,33	0,46	0,56	0,65	0,80	1,0	1,2	1,5	●	●	●	
▼	▼					103	1,2	0,65	0,92	1,1	1,30	1,6	2,1	2,4	2,9	●	●	●	
▼	▼					107	1,3	0,85	1,2	1,5	1,7	2,1	2,7	3,2	3,8	●	●	●	
▼	▼					111	1,4	1,1	1,5	1,8	2,1	2,6	3,3	3,9	4,7	●	●	●	
▼	▼					115	1,6	1,3	1,8	2,2	2,5	3,1	4,0	4,7	5,6	●	●	●	
▼	▼					120	1,8	1,5	2,1	2,6	3,0	3,7	4,7	5,6	6,7	●	●	●	
▼	▼					125	1,9	1,8	2,5	3,0	3,5	4,3	5,5	6,5	7,8	●	●	●	
▼	▼	▼				135	2,2	2,3	3,2	3,9	4,5	5,5	7,1	8,4	10,1	●	●	●	
▼	▼	▼				146	2,4	2,8	4,0	4,8	5,6	6,9	8,9	10,5	13	●	●	●	
▼	▼	▼				152	2,6	3,1	4,4	5,4	6,2	7,6	9,8	11,6	14	●	●	●	
▼	▼	▼				170	2,9	4,0	5,7	6,9	8,0	9,8	13	15	18	●	●	●	
▼	▼	▼	▼			184	3,2	4,7	6,6	8,1	9,4	11,5	15	18	21	●	●	●	
▼	▼	▼	▼			200	3,5	5,5	7,8	9,5	11,0	13	17	21	25	●	●	●	
	▼	▼	▼			217	3,8	6,4	9,0	11,0	13	16	20	24	28	●	●	●	
	▼	▼	▼			245	4,2	8,0	11,3	14	16	20	25	30	36	●	●	●	
	▼	▼	▼			270	4,5	9,0	13	16	18	22	28	34	40	●	●	●	
	▼	▼	▼			310	4,9	11,0	16	19	22	27	35	41	49	●	●	●	
		▼	▼			400	5,9	16	22	27	31	38	49	58	69	●	●	●	
		▼	▼			414	6,4	19	27	33	38	47	60	71	85	●	●	●	
		▼	▼			424	6,9	22	30	37	43	53	68	80	96	●	●	●	
		▼	▼	▼		442	7,5	26	37	45	52	64	82	97	116	●	●	●	
		▼	▼	▼		460	8,2	30	42	52	60	73	95	112	134	●	●	●	
		▼	▼	▼		488	9,1	37	52	64	74	91	117	138	165	●	●	●	
			▼	▼	▼	528	10,3	47	66	81	94	115	149	176	210	●	●	●	
			▼	▼	▼	562	11,3	55	78	95	110	135	174	206	246	●	●	●	
			▼	▼	▼	600	11,9	63	88	108	125	153	198	234	280	●	●	●	
			▼	▼	▼	630	12,8	75	106	130	150	184	237	281	335	●	●	●	
			▼	▼	▼	676	14,8	98	139	170	196	240	310	367	438	●	●	●	
			▼	▼	▼	715	16,9	118	166	204	235	288	372	440	525	●	●	●	
			▼	▼	▼	733	17,4	127	179	219	253	310	400	473	566	●	●	●	

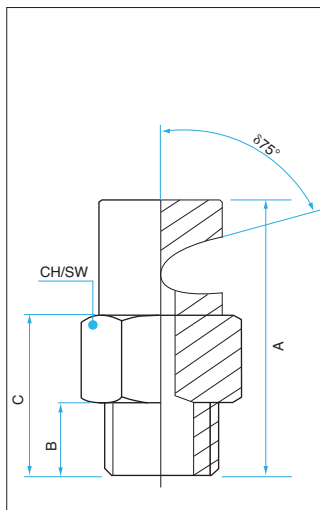

Tipo / Type OL δ 75°

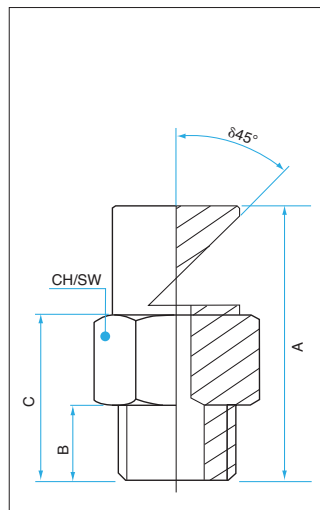

Tipo / Type OL δ 45°

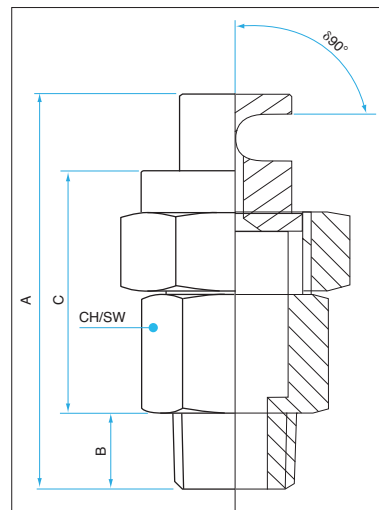

Tipo / Type OL δ 90°

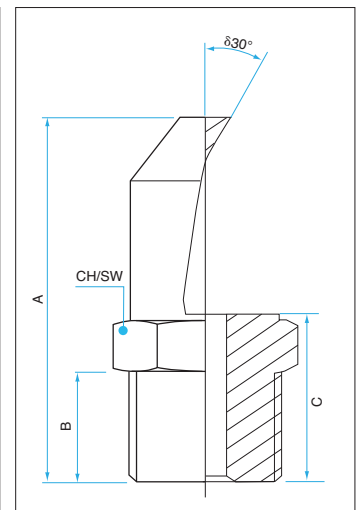

Tipo / Type OL δ 30°

DIMENSIONI DIMENSIONS	OL δ 75° - OL δ 45°						OL δ 30°				OL δ 90°	
	1/8"	1/4"	3/8"	1/2"	3/4"	1"	1/8"	1/4"	3/8"	1/2"	1/4"	3/8"
A	20	28	33	38	50	60	35	37	40	43	43	43
B	6	9	9	12	14	17	9	11	13	15	9	9
C	12	16	18	21	23	27	15	17	20	21	26	26
CH/SW	10	14	17	22	30	36	10	14	17	22	17	17



UGELLI ASSIALI A GETTO PIATTO - SERIE OLL - OLT - OLTl

AXIAL FEED FLAT-JET NOZZLES – OLL - OLT- OLTl SERIES

OL



Tipo / Type OLL y



Tipo / Type OLT y



Tipo / Type OLTl y

CARATTERISTICHE

- Ricavati da barra esagonale e lavorati di precisione soprattutto sulla superficie di deflessione
- La presenza di un solo foro di passaggio evita la possibilità di intasamento degli ugelli
- Il getto ha distribuzione uniforme ed estremità ben delineate
- Gocce di media grandezza
- Media forza d'impatto
- Tipo OLL: angolo di spruzzo fino a 180°
- Tipo OLT: angolo di spruzzo fino a 340°

CHARACTERISTICS

- Made out of hexagonal bar and precision machined, above all on the deflection surface
- Non-clogging characteristics owing to the presence of one passage hole only
- The jet is flat and wide with well delineated ends
- Medium impact force
- Medium-sized droplets
- The OLL type: spray angle up to 180°
- The OLT type: spray angle up to 340°

CODE STD. MAT.
02 AISI 316
04 AISI 303
06 Ottone/Brass
08 PVC

APPLICAZIONI CONSIGLIATE

- Lavaggio materiali
- Raffreddamento serbatoi
- Sistemi antincendio

TYPICAL APPLICATIONS

- Materials washing
- Tanks cooling
- Fire fighting systems

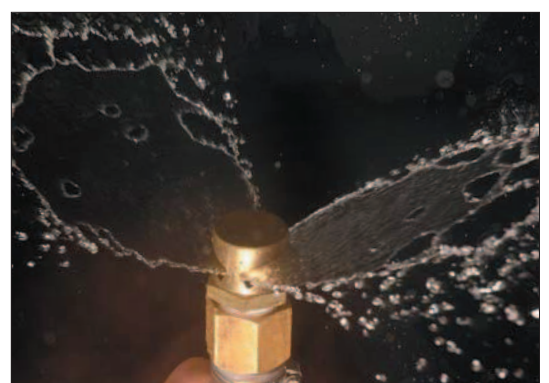

Ugelli OL, alla pressione di esercizio di 0,5 bar.

OL Spray nozzle - pressure 0,5 bar,



UGELLI ASSIALI A GETTO PIATTO - SERIE OLL - OLT - OLT-I

AXIAL FEED FLAT-JET NOZZLES – OLL - OLT- OLT-I SERIES

OL

DATI OPERATIVI - OPERATIVE DATA

TIPO / TYPE OLL - OLT - OLT-I Dimensione raccordo - Thread dimension						CODICE PORTATA FLOW CODE	PORTATA / FLOW l/min									AMPIEZZA ANGOLO DI SPRUZZO SPRAY ANGLE WIDTH	
1/8"	1/4"	3/8"	1/2"	3/4"	1"		Ø mm.	0,5 bar	1 bar	1,5 bar	2 bar	3 bar	5 bar	7 bar	10 bar	170° OLL	340° OLT-I
▼	▼					030	0,6	0,15	0,21	0,26	0,30	0,37	0,47	0,6	0,7	●	●
▼	▼					065	0,8	0,33	0,46	0,56	0,65	0,80	1,0	1,2	1,5	●	●
▼	▼					103	1,2	0,65	0,92	1,1	1,30	1,6	2,1	2,4	2,9	●	●
▼	▼					107	1,3	0,85	1,2	1,5	1,7	2,1	2,7	3,2	3,8	●	●
▼	▼					111	1,4	1,1	1,5	1,8	2,1	2,6	3,3	3,9	4,7	●	●
▼	▼					115	1,6	1,3	1,8	2,2	2,5	3,1	4,0	4,7	5,6	●	●
▼	▼					120	1,8	1,5	2,1	2,6	3,0	3,7	4,7	5,6	6,7	●	●
▼	▼					125	1,9	1,8	2,5	3,0	3,5	4,3	5,5	6,5	7,8	●	●
▼	▼	▼				135	2,2	2,3	3,2	3,9	4,5	5,5	7,1	8,4	10,1	●	●
▼	▼	▼				146	2,4	2,8	4,0	4,8	5,6	6,9	8,9	10,5	13	●	●
▼	▼	▼				152	2,6	3,1	4,4	5,4	6,2	7,6	9,8	11,6	14	●	●
▼	▼	▼				170	2,9	4,0	5,7	6,9	8,0	9,8	13	15	18	●	●
▼	▼	▼	▼			184	3,2	4,7	6,6	8,1	9,4	11,5	15	18	21	●	●
▼	▼	▼	▼			200	3,5	5,5	7,8	9,5	11,0	13	17	21	25	●	●
	▼	▼	▼			217	3,8	6,4	9,0	11,0	13	16	20	24	28	●	●
	▼	▼	▼			245	4,2	8,0	11,3	14	16	20	25	30	36	●	●
	▼	▼	▼			270	4,5	9,0	13	16	18	22	28	34	40	●	●
	▼	▼	▼			310	4,9	11,0	16	19	22	27	35	41	49	●	●
		▼	▼			400	5,9	16	22	27	31	38	49	58	69	●	●
		▼	▼			414	6,4	19	27	33	38	47	60	71	85	●	●
		▼	▼			424	6,9	22	30	37	43	53	68	80	96	●	●
			▼			442	7,5	26	37	45	52	64	82	97	116	●	●
			▼			460	8,2	30	42	52	60	73	95	112	134	●	●
			▼			488	9,1	37	52	64	74	91	117	138	165	●	●
				▼		528	10,3	47	66	81	94	115	149	176	210	●	●
				▼	▼	562	11,3	55	78	95	110	135	174	206	246	●	●
				▼	▼	600	11,9	63	88	108	125	153	198	234	280	●	●
				▼	▼	630	12,8	75	106	130	150	184	237	281	335	●	●
				▼	▼	676	14,8	98	139	170	196	240	310	367	438	●	●
				▼	▼	715	16,9	118	166	204	235	288	372	440	525	●	●
				▼	▼	733	17,4	127	179	219	253	310	400	473	566	●	●

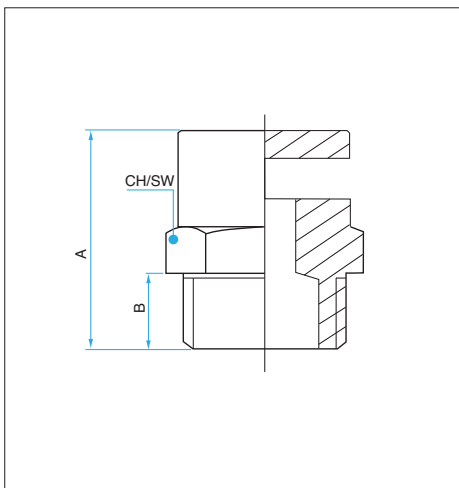

Tipo / Type OLL y

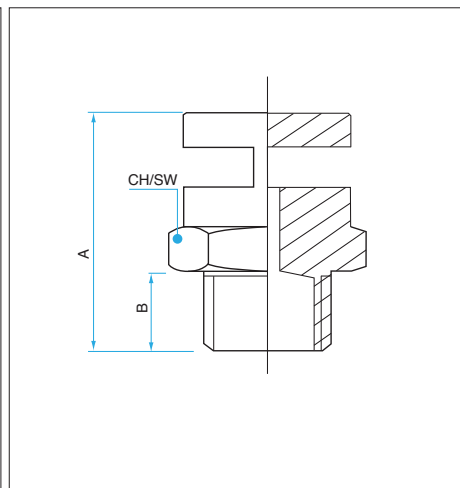

Tipo / Type OLT y

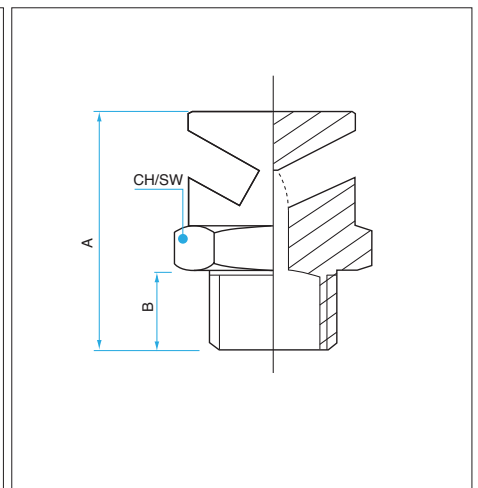

Tipo / Type OLT-I y

DIMENSIONI DIMENSIONS	OLL - OLT - OLT-I					
	1/8" y	1/4" y	3/8" y	1/2" y	3/4" y	1" y
A	20	25	30	40	50	40
B	8	8	10	12	15	20
CH/SW	10	14	17	22	30	36



UGELLI ASSIALI A GETTO PIATTO - SERIE OLP

AXIAL FEED FLAT-JET NOZZLES – OLP SERIES

OL



Tipo / Type OLP y

CARATTERISTICHE

- Ricavati da barra e lavorati di precisione soprattutto sulla superficie di deflessione
- Il getto ha distribuzione uniforme ed estremità ben delineate
- Gocce di media grandezza
- Buona forza d'impatto del getto
- La presenza di un solo foro di passaggio evita la possibilità di intasamento degli ugelli

APPLICAZIONI CONSIGLIATE

- Sistemi di pulizia, lavaggio, sgrassaggio e fosfatazione

CHARACTERISTICS

- Made out of bar and precision machined, above all on the deflection surface
- The jet has a uniform distribution and well-delineated ends
- Medium-sized droplets
- Good impact force of the jet
- Non-clogging characteristics owing to the presence of one passage hole only

TYPICAL APPLICATIONS

- Cleaning, washing, degreasing and phosphating systems

CODE STD. MAT.
02 AISI 316
04 AISI 303
06 Ottone/Brass
08 PVC



DATI OPERATIVI - OPERATIVE DATA

TIPO/TYPE OLP y Dimensione raccordo - Thread dimension				CODICE PORTATA FLOW CODE	PORTATA / FLOW l/min										AMPIEZZA ANGOLO DI SPRUZZO SPRAY ANGLE WIDTH		
1/8"	1/4"	3/8"	1/2"		Ø mm.	0,5 bar	1 bar	1,5 bar	2 bar	3 bar	5 bar	7 bar	10 bar	15°	35°	50°	
▼				120	1,8	1,5	2,1	2,6	3,0	3,7	4,7	5,6	6,7	●	●	●	
▼				125	1,9	1,8	2,5	3,0	3,5	4,3	5,5	6,5	7,8	●	●	●	
▼				135	2,2	2,3	3,2	3,9	4,5	5,5	7,1	8,4	10,1	●	●	●	
▼				146	2,4	2,8	4,0	4,8	5,6	6,9	8,9	10,5	13	●	●	●	
▼	▼			152	2,6	3,1	4,4	5,4	6,2	7,6	9,8	11,6	14	●	●	●	
▼	▼			170	2,9	4,0	5,7	6,9	8,0	9,8	13	15	18	●	●	●	
▼	▼	▼		184	3,2	4,7	6,6	8,1	9,4	11,5	15	18	21	●	●	●	
▼	▼	▼		200	3,5	5,5	7,8	9,5	11,0	13	17	21	25	●	●	●	
	▼	▼		217	3,8	6,4	9,0	11,0	13	16	20	24	28	●	●	●	
	▼	▼	▼	245	4,2	8,0	11,3	14	16	20	25	30	36	●	●	●	
	▼	▼	▼	270	4,5	9,0	13	16	18	22	28	34	40	●	●	●	
	▼	▼	▼	310	4,9	11,0	16	19	22	27	35	41	49	●	●	●	
		▼	▼	400	5,9	16	22	27	31	38	49	58	69	●	●	●	
		▼	▼	414	6,4	19	27	33	38	47	60	71	85	●	●	●	
			▼	424	6,9	22	30	37	43	53	68	80	96	●	●	●	
			▼	442	7,5	26	37	45	52	64	82	97	116	●	●	●	
			▼	460	8,2	30	42	52	60	73	95	112	134	●	●	●	



UGELLI ASSIALI A GETTO PIATTO - SERIE OLP AXIAL FEED FLAT-JET NOZZLES – OLP SERIES

OL



Tipo / Type OLP pressione/pressure 0,3 BAR



Tipo / Type OLP pressione/pressure 0,3 BAR

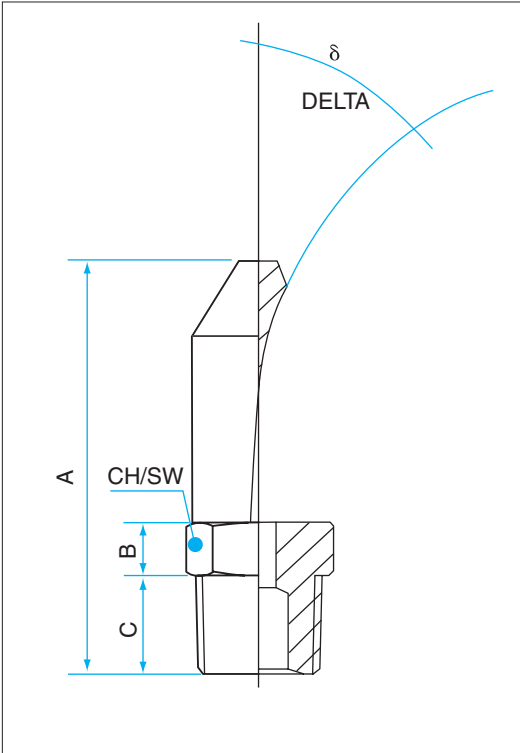

α	δ
15°	8°÷10°
35°	12°÷15°
45°	18°÷21°

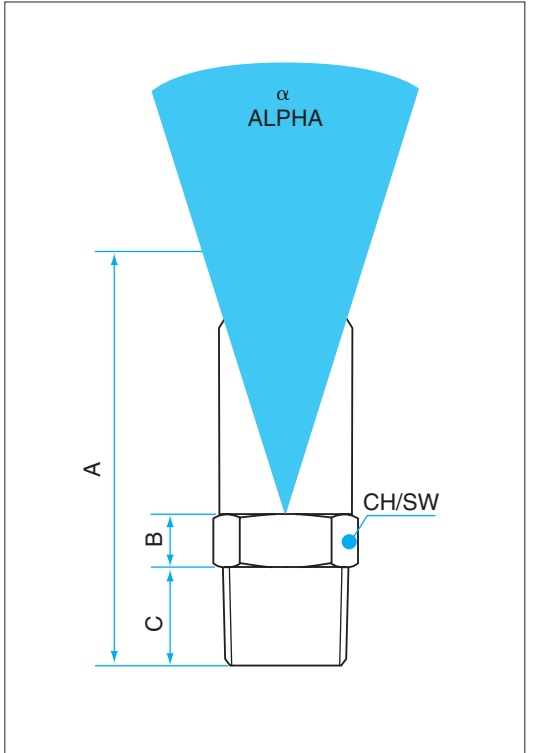

DIMENSIONI DIMENSIONS	OLP			
	1/8" y	1/4" y	3/8" y	1/2" y
A	40	45	55	75
B	5	7	9	10
C	10	12	12	15
CH / SW	10	14	17	22



Tipo / Type OLP
codice/code 146
pressione/pressure 15 BAR



UGELLI AUTOROTANTI A GETTO PIATTO - SERIE GR

SELF-ROTATING NOZZLES – GR SERIES

GR



Tipo / Type GR y



Tipo / Type GR x

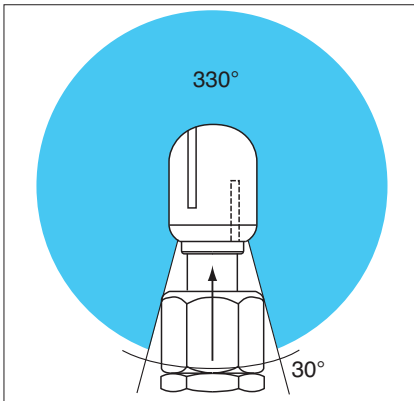

Codice/code "T"
Sezione di copertura totale
Total covering section

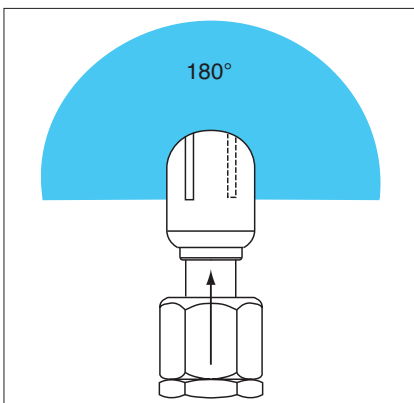

Codice/Code "U"
Sezione di copertura frontale
Frontal covering section



Immagine di un GR Cod. "T" / codice portata 224, alla pressione di 0,01 bar, durante la fase iniziale della rotazione.

In photo GR code "T" / Flow code 224, at pressure of 0,01 bar, during the first phase of the rotation.

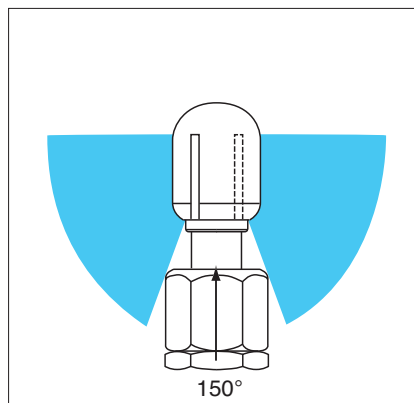

Codice/Code "D"
Sezione di copertura posteriore
Back covering section

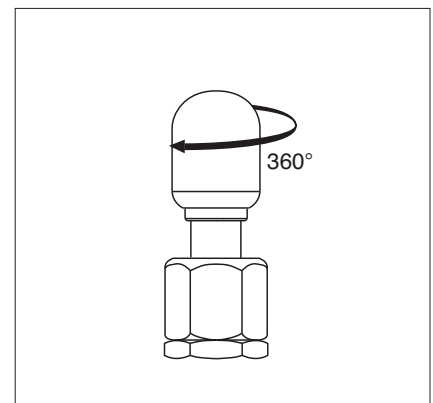

Rotazione in senso orario
Clockwise rotation 360°

CARATTERISTICHE

- Appositamente studiati per effettuare il completo lavaggio interno di serbatoi e fusti di piccole e medie dimensioni
- Le teste rotanti hanno due fresature dalle quali fuoriescono due getti piatti ad alto impatto
- La rotazione delle teste di spruzzo è impressa dallo stesso liquido di lavaggio
- Massima sicurezza e semplicità d'uso, poiché non viene impiegato alcun motore o meccanismo
- Ricavati da barra
- Pressione di esercizio consigliata: min. 0,5 bar – max 20 bar
- A richiesta le piste di rotolamento dei cuscinetti sono costruite in acciaio inox temprato, per ovviare a problemi di corrosione ed usura
- Raccordo standard: BSP, altre filettature a richiesta

CHARACTERISTICS

- They have been specially designed for the full inside washing of tanks, drums and barrels, having small and medium dimensions
- The rotating heads have two millings, from which come out two flat jets, having high impact force
- The rotation of the spray heads is caused by the washing liquid
- Utmost security and an easier use, because no motor or mechanism are used
- Made out of bar
- Suggest operating pressure: min. 0,5 bar – max 20 bar
- On request we supply hardened stainless steel rolling races for bearings, to avoid corrosion and wear problems
- Standard thread: BSP, other threads on request

CODE STD.
MAT.

02 AISI 316
06 Ottone/Brass
09 Delrin
36 Teflon



UGELLI AUTOROTANTI A GETTO PIATTO - SERIE GR

SELF-ROTATING NOZZLES – GR SERIES

GR

DATI OPERATIVI - OPERATIVE DATA

TIPO / TYPE GR x - y Dimensione raccordo / Thread dimension				CODICE PORTATA FLOW CODE	PORTATA / FLOW l/min						
3/8"	1/2"	3/4"	1"		0,5 bar	1 bar	1,5 bar	2 bar	3 bar	5 bar	7 bar
▼	▼			122	1,6	2,3	2,8	3,2	3,9	5,1	6,0
▼	▼			159	3,5	4,9	6,0	6,9	8,5	10,9	12,9
▼	▼			148	2,9	4,1	5,0	5,8	7,1	9,2	10,9
▼	▼			174	4,2	5,9	7,3	8,4	10,3	13	16
▼	▼			188	4,9	6,9	8,5	9,8	12,0	15	18
▼	▼			212	6,1	8,6	10,6	12,2	15	19	23
▼	▼			224	6,7	9,5	11,6	13,4	16	21	25
▼	▼			260	8,5	12,0	15	17,0	21	27	32
▼	▼			282	9,6	14	17	19,2	24	30	36
▼	▼			301	10,6	15	18	21,1	26	33	39
▼	▼			308	10,9	15	19	21,8	27	34	41
▼	▼			331	12	17	21	24,1	30	38	45
▼	▼			368	14	20	24	27,8	34	44	52
▼	▼			408	18	25	30	35,0	43	55	65
▼	▼			424	22	30	37	43,0	53	68	80
		▼	▼	438	25	35	43	50,0	61	79	94
		▼	▼	460	30	42	52	60,0	73	95	112
		▼	▼	480	35	49	61	70,0	86	111	131
		▼	▼	500	40	57	69	80,0	98	126	150
		▼	▼	522	45	64	78	90,0	110	142	168
		▼	▼	540	50	71	87	100,0	122	158	187
		▼	▼	583	60	85	104	120,0	147	190	224
		▼	▼	620	70	99	121	140,0	171	221	262
		▼	▼	640	80	113	139	160,0	196	253	299

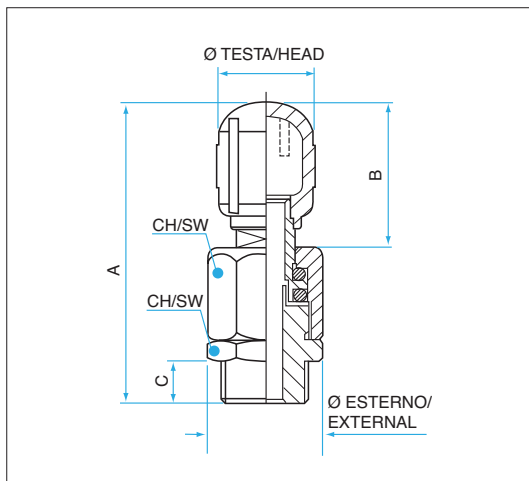

Tipo / Type GR y

DIMENSIONI DIMENSIONS	RACCORDO GAS CILINDRICO BSP BSP THREAD			
	3/8" x-y	1/2" x-y	3/4" x-y	1" x-y
A	70	70	100	100
B	33	33	50	50
C	10	10	10	10
CH/SW	24	24	36	36
Ø TESTA/HEAD	23,6	23,6	35	35
Ø EST. STANDARD	27,5	27,5	41	41
Ø EXT. STANDARD				
Ø EST. A RICHIESTA	25	25	37	37
Ø EXT. ON REQUEST				

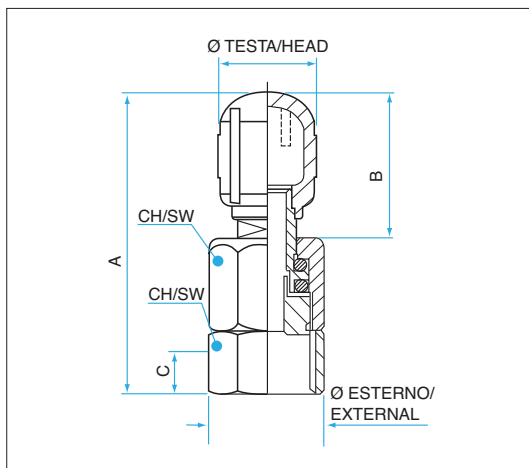

Tipo / Type GR x



Versione speciale
Special version

UGELLI A GETTO RETTILINEO - SERIE F3 - F3S

RECTLINEAR-JET NOZZLES – F3 - F3S SERIES

F3

CARATTERISTICHE

- Ricavati da barra esagonale e lavorati di precisione.
- Ottimizzazione del flusso di liquido, per mantenere costanti le caratteristiche di spruzzo
- Getto rettilineo compatto ad alta efficienza.
- Elevata forza di impatto
- Tipo F3S sfera ugello: possibilità di orientare con precisione la direzione del getto in base alle esigenze di installazione

CHARACTERISTICS

- Made out of hexagonal bar and precision machined.
- A particular technique enables you to get to an optimal liquid flow and to a jet that keeps constant its spray characteristics
- Rectilinear, compact and highly effective jet
- High impact force
- F3s type ball-nozzles: possibility to adjust the direction of the jet precisely, according to your mounting needs

CODE STD. MAT.
02 AISI 316
04 AISI 303
06 Ottone/Brass

APPLICAZIONI CONSIGLIATE

- Per tutte le operazioni di pulizia
- Per tagliare e separare con il getto
- Per mescolare o tenere in agitazione vernici o liquidi in genere

TYPICAL APPLICATIONS

- Every cleaning operations
- To cut and to separate by jet
- To mix or to keep paints or liquid in general in agitation

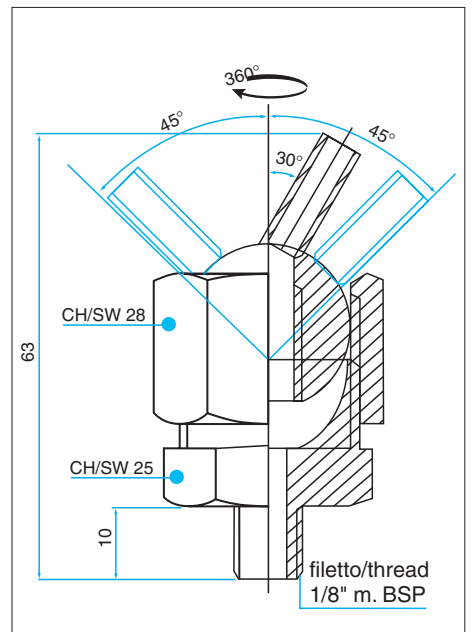
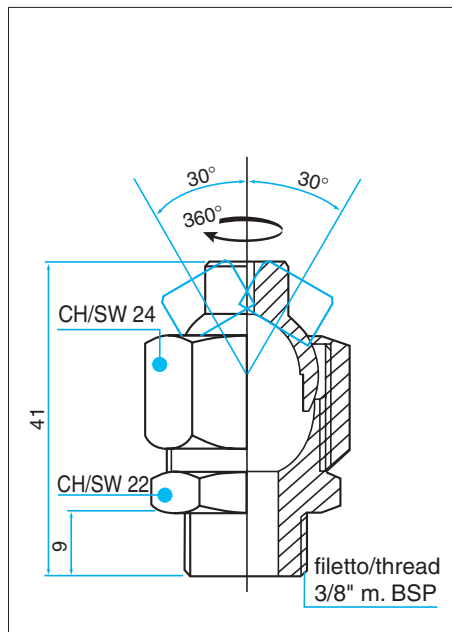
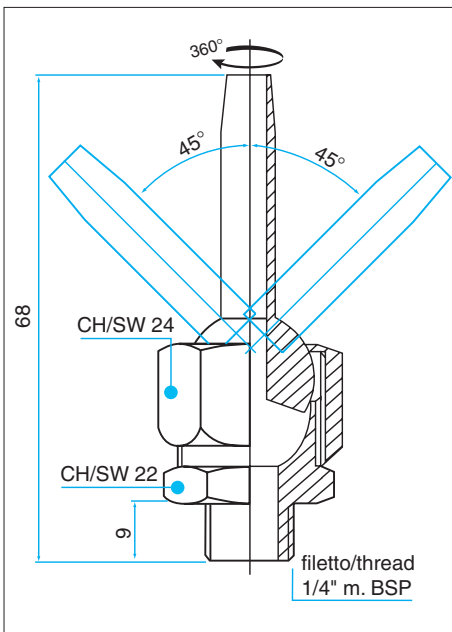
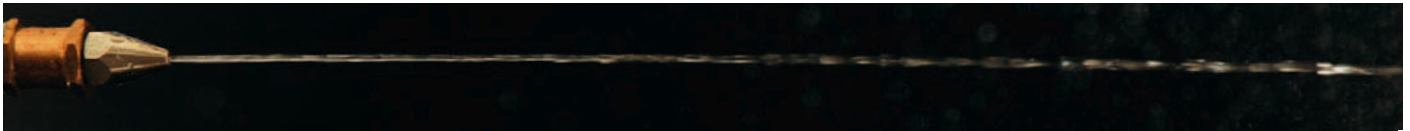

UGELLI A GETTO RETTILINEO - SERIE F3 - F3S RECTLINEAR-JET NOZZLES – F3 - F3S SERIES

F3

DATI OPERATIVI - OPERATIVE DATA

TIPO / TYPE F3-F3S y Dimensione raccordo Thread dimension			CODICE PORTATA FLOW CODE	PORTATA / FLOW l/min											AMPIEZZA ANGOLO DI SPRUZZO SPRAY ANGLE WIDTH
1/8"	1/4"	3/8"		Ø mm	0,5 bar	1 bar	1,5 bar	2 bar	3 bar	4 bar	5 bar	7 bar	10 bar	15 bar	
▼	▼	▼	045	0,7	0,23	0,32	0,39	0,45	0,55	0,64	0,71	0,84	1,0	1,2	0°
▼	▼	▼	087	0,9	0,44	0,62	0,75	0,87	1,1	1,2	1,4	1,6	1,9	2,4	
▼	▼	▼	102	1,1	0,60	0,85	1,0	1,2	1,5	1,7	1,9	2,2	2,7	3,3	
▼	▼	▼	104	1,2	0,70	1,0	1,2	1,4	1,7	2,0	2,2	2,6	3,1	3,8	
▼	▼	▼	106	1,4	0,80	1,1	1,4	1,6	2,0	2,3	2,5	3,0	3,6	4,4	
▼	▼	▼	113	1,6	1,2	1,6	2,0	2,3	2,8	3,3	3,6	4,3	5,1	6,3	
▼	▼	▼	122	1,9	1,6	2,3	2,8	3,2	3,9	4,5	5,1	6,0	7,2	8,8	
▼	▼	▼	126	2,0	1,8	2,5	3,1	3,6	4,4	5,1	5,7	6,7	8,0	9,9	
▼	▼	▼	132	2,2	2,1	3,0	3,6	4,2	5,1	5,9	6,6	7,9	9,4	11,5	
▼	▼	▼	138	2,5	2,4	3,4	4,2	4,8	5,9	6,8	7,6	9,0	10,7	13	
▼	▼	▼	146	2,7	2,8	4,0	4,8	5,6	6,9	7,9	8,9	10,5	13	15	
▼	▼	▼	154	3,0	3,2	4,5	5,5	6,4	7,8	9,1	10,1	12,0	14	18	
▼	▼	▼	164	3,3	3,7	5,2	6,4	7,4	9,1	10,5	11,7	14	17	20	
▼	▼	▼	186	3,5	4,8	6,8	8,3	9,6	11,8	14	15	18	21	26	
▼	▼	▼	205	3,8	5,8	8,1	10,0	11,5	14	16	18	22	26	31	
▼	▼	▼	225	4,0	6,8	9,5	11,7	13,5	17	19	21	25	30	37	
▼	▼	▼	255	4,5	8,3	11,7	14	16,5	20	23	26	31	37	45	
▼	▼	▼	320	5,0	11,5	16	20	23	28	33	36	43	51	63	
▼	▼	▼	360	5,5	14	19	23	27	33	38	43	51	60	74	

